

COOLCOX®

东莞市奇凌电子科技有限公司
COOLCOX LIMITED

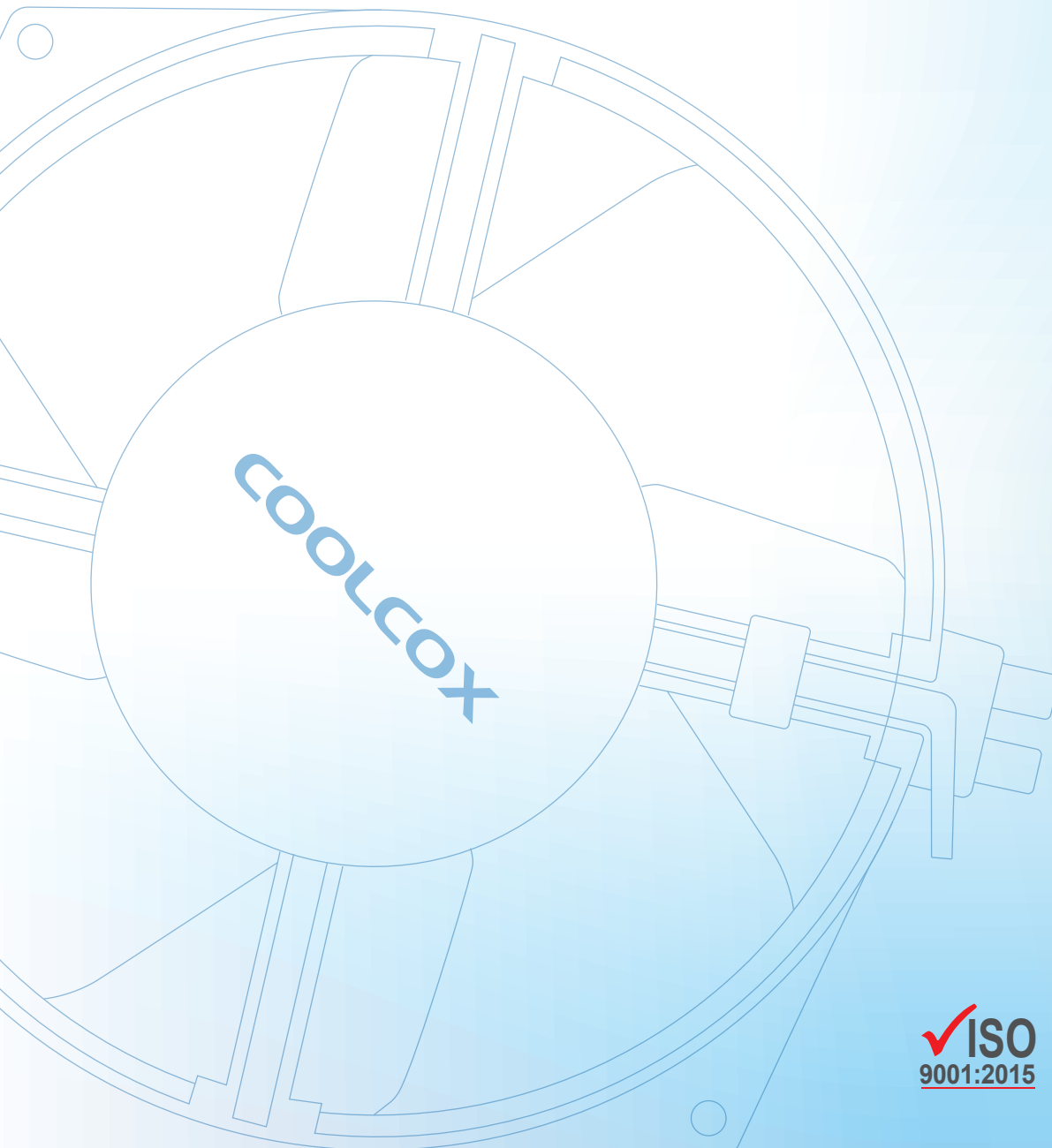

公司简介

奇凌电子创立于2008年，致力于散热产品的研发与生产，是具有“自主品牌和知识产权”的高新科技企业。

研发制造基地位于东莞市望牛墩镇，厂房面积16,000平方米，员工700余人。公司已通过ISO9001、ISO14001、IATF16949、QC080000管理体系认证，产品符合UL、TUV、CE、CQC等安规认证。

公司拥有先进的自动化设备和一流的制造能力，以及严格的品质管理体系，持续为全球客户提供高性能的轴流风扇、鼓风机、散热器、电机等产品，广泛应用于计算机、网络设备、家用电器、医疗设备、安防产品、自控系统、3D打印机、投影仪、新能源等领域。

公司坚持技术创新和品质保证，以全面高效的散热产品和解决方案，为客户实现价值增长。



II Introductions (风扇介绍)

- All parts are in conformity with RoHS2.0 standard
风扇所有部件符合RoHS2.0标准
- AC100-120V or 220-240V or 380V is optional
可选择交流100-120V或220-240V或380V
- Impedance protection is available for motor
马达有阻抗保护功能
- 2-Ball Bearing supports long life expectancy
双滚珠轴承支持长寿命工作

II Part Number Definition (产品型号命名规则)

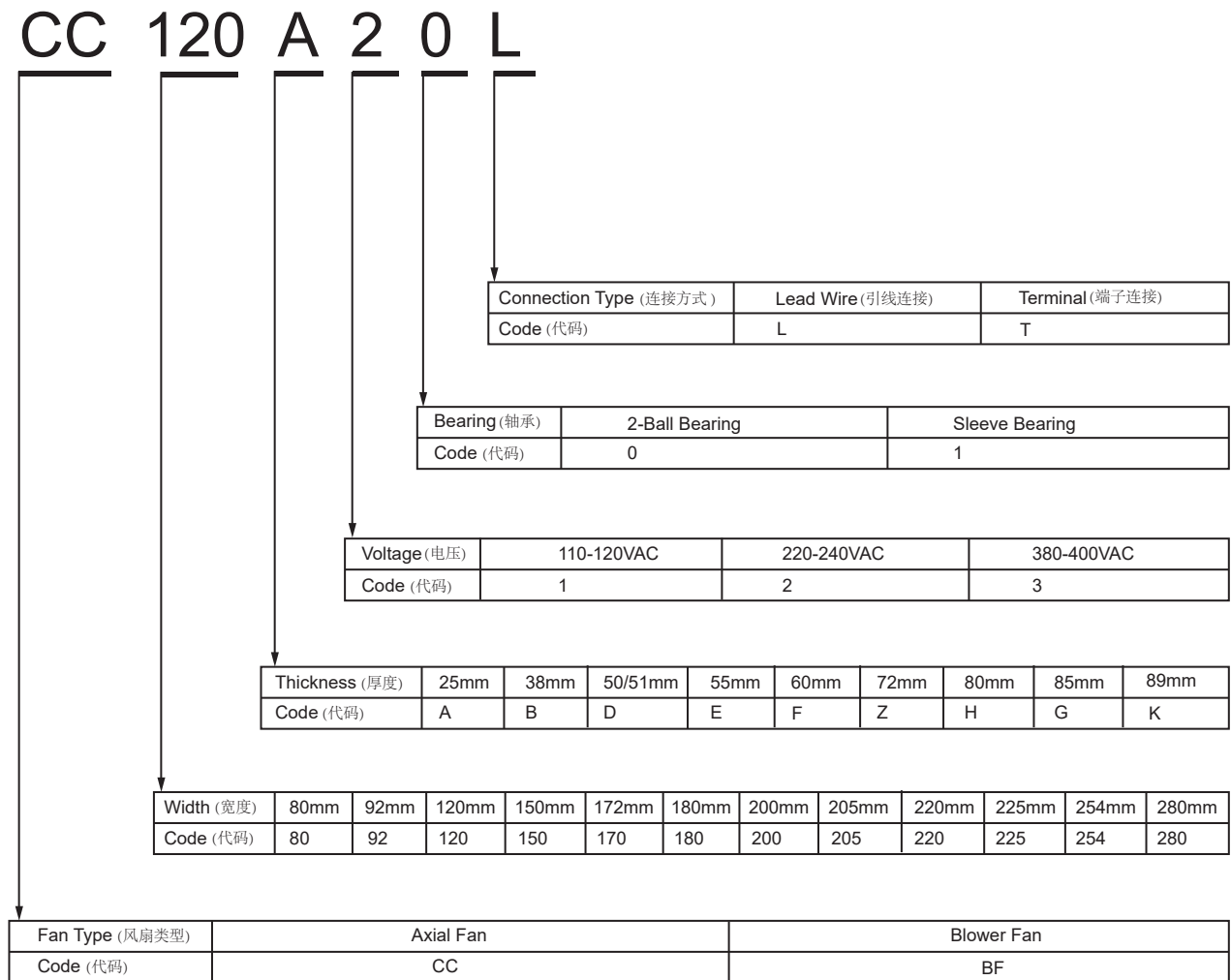

AC Axial Fan 80x80x25mm

■ 尺寸图 (DIMENSION DRAWING)

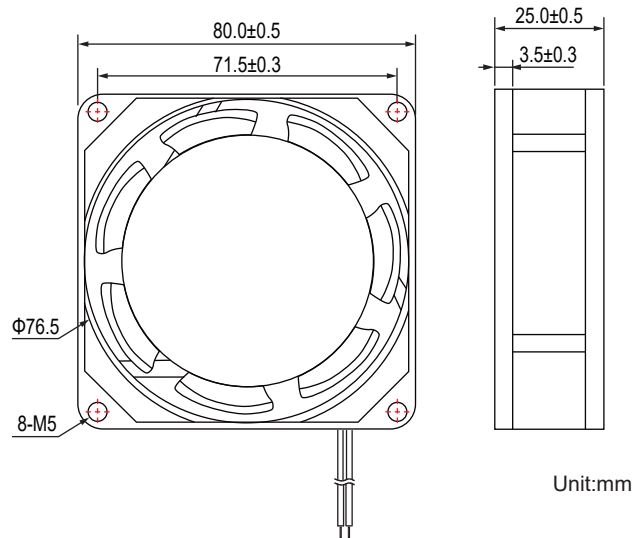

- * 轴承类型:滚珠轴承 (Bearing type:2-ball)
- * 材料(Material):
框(Frame):铝合金Aluminum Alloy
扇叶(Impeler):PBT(UL94V-0)
- * 引线(Lead wire):
UL1430 AWG #22(Optional)
- * 马达(Motor):罩极马达Shaded pole
- * 保护(Protection): Impedance protection
- * 重量(Weight):260g

■ 风压&风量曲线图 P and Q CURVE

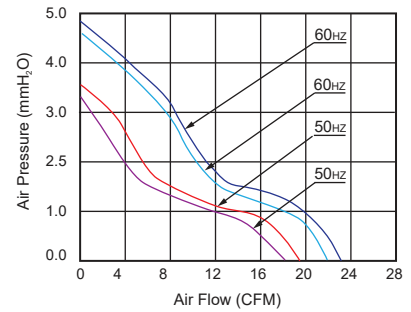

型号 Model	轴承类型 Bearing Type	电压	频率	电流	功率	转速	风量	风压	噪音
		VAC	Hz	Amp	Watt	RPM	CFM	MM-H ₂ O	dBA
CC80A10L(T)	2-Ball	100-120	50/60	0.12/0.10	14.0/13.5	2550/2900	18/22	3.3/4.6	29/33
CC80A20L(T)	2-Ball	220-240	50/60	0.07/0.06	14.0/13.5	2550/2900	18/22	3.3/4.6	29/33
CC80A10L(T)	2-Ball	100-120	50/60	0.18/0.14	14.0/11.0	2600/3100	19/23	3.5/4.8	30/35
CC80A20L(T)	2-Ball	220-240	50/60	0.09/0.07	14.0/11.0	2600/3100	19/23	3.5/4.8	30/35

- * 以上为额定电压下的常规参数(All readings are typical values at rated voltage)
- * 规格如有变动不另行通知(Specifications are subjected to change without prior notice)

AC Axial Fan 80x80x38mm

■ 尺寸图 (DIMENSION DRAWING)

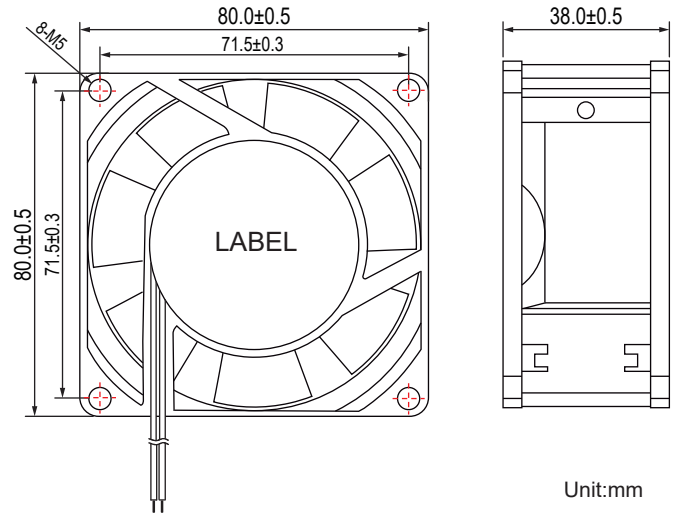

- * 轴承类型: 滚珠轴承
(Bearing type: 2-ball)
- * 材料(Material):
框(Frame): 铝合金Aluminum Alloy
扇叶(Impeller): PBT(UL94V-0)
- * 引线(Lead wire):
UL1430 AWG #22 or equivalent
- * 马达(Motor): 罩极马达Shaded pole
- * 保护(Protection): Impedance protection
- * 重量(Weight): 370g

■ 风压&风量曲线图 P and Q CURVE

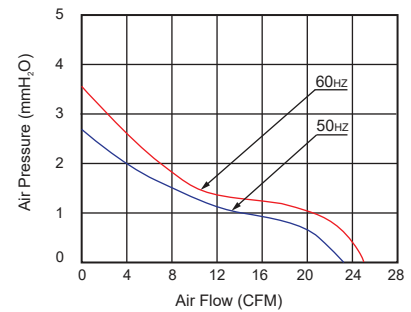

型号 Model	轴承类型 Bearing Type	电压 Voltage	频率 Frequency	电流 Current	功率 Input Power	转速 Speed	风量 Air Flow	风压 Static Pressure	噪音 Noise Level
		VAC	Hz	Amp	Watt	RPM	CFM	MM-H ₂ O	dBA
CC80B10L(T)	2-Ball	100-120	50/60	0.15/0.13	16.0/14.0	2,400/2800	23/26	2.6/3.4	27/31
CC80B20L(T)	2-Ball	220-240	50/60	0.08/0.07	11.0/9.00	2,400/2800	23/26	2.6/3.4	27/31

- * 以上为额定电压下的常规参数(All readings are typical values at rated voltage)
- * 规格如有变动不另行通知(Specifications are subjected to change without prior notice)

AC Axial Fan 92x92x25mm

■ 尺寸图 (DIMENSION DRAWING)

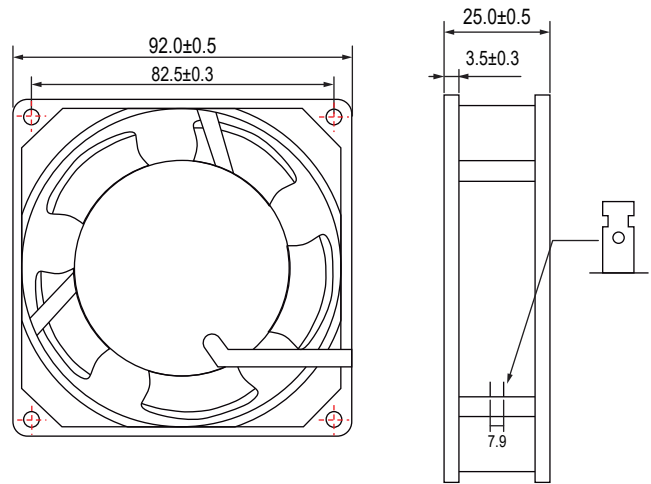

Unit:mm

- * 轴承类型:滚珠轴承 (Bearing type:2-ball)
- * 材料(Material):
框(Frame):铝合金Aluminum Alloy
扇叶(Impeller):PBT(UL94V-0)
- * 引线(Lead wire):
UL1430 AWG #22(Optional)
- * 马达(Motor):罩极马达Shaded pole
- * 保护(Protection): Impedance protection
- * 重量(Weight):290g

■ 风压&风量曲线图 P and Q CURVE

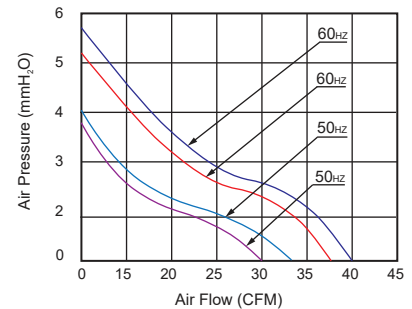

型号 Model	轴承类型 Bearing Type	电压 Voltage	频率 Frequency	电流 Current	功率 Input Power	转速 Speed	风量 Air Flow	风压 Static Pressure	噪音 Noise Level
		VAC	Hz	Amp	Watt	RPM	CFM	MM-H ₂ O	dBA
CC92A10L(T)	2-Ball	100-120	50/60	0.12/0.10	14.0/13.5	2550/2900	30/37	3.8/5.6	32/37
CC92A20L(T)	2-Ball	220-240	50/60	0.07/0.06	14.0/13.5	2550/2900	30/37	3.8/5.6	32/37
CC92A10L(T)	2-Ball	100-120	50/60	0.18/0.14	14.0/11.0	2600/3000	33/40	4.0/5.8	35/40
CC92A20L(T)	2-Ball	220-240	50/60	0.09/0.07	14.0/11.0	2600/3000	33/40	4.0/5.8	35/40

- * 以上为额定电压下的常规参数(All readings are typical values at rated voltage)
- * 规格如有变动不另行通知(Specifications are subjected to change without prior notice)

AC Axial Fan 92x92x38mm

■ 尺寸图 (DIMENSION DRAWING)

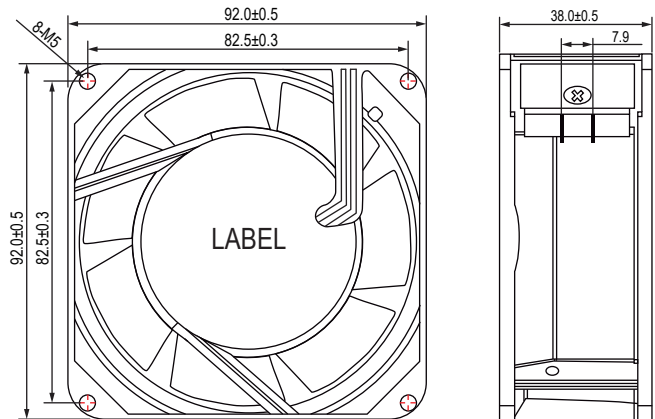

Unit:mm

- * 轴承类型:滚珠轴承 (Bearing type:2-ball)
- * 材料(Material):
 框 (Frame):铝合金Aluminum Alloy
 扇叶 (Impeller):PBT(UL94V-0)
- * 引线(Lead wire):
 UL1430 AWG #22(Optional)
- * 马达(Motor):罩极马达Shaded pole
- * 保护(Protection): Impedance protection
- * 重量(Weight):390g

■ 风压&风量曲线图 P and Q CURVE

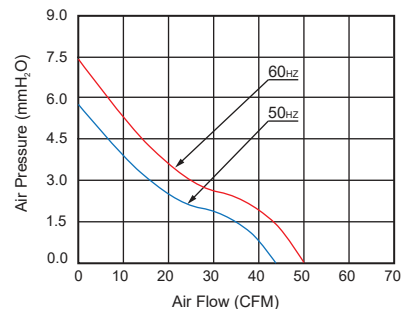

型号 Model	轴承类型 Bearing Type	电压 Voltage	频率 Frequency	电流 Current	功率 Input Power	转速 Speed	风量 Air Flow	风压 Static Pressure	噪音 Noise Level
		VAC	Hz	Amp	Watt	RPM	CFM	MM-H ₂ O	dBA
CC92B10L(T)	2-Ball	100-120	50/60	0.25/0.18	15.0/11.0	2300/2700	43/50	5.3/7.4	43/50
CC92B20L(T)	2-Ball	220-240	50/60	0.13/0.10	15.0/11.0	2300/2700	43/50	5.3/7.4	43/50
CC92B30L(T)	2-Ball	380	50	0.06	12.0	2300	43	5.3	43

- * 以上为额定电压下的常规参数 (All readings are typical values at rated voltage)
- * 规格如有变动不另行通知 (Specifications are subjected to change without prior notice)

AC Axial Fan 110x110x25mm

■ 尺寸图 (DIMENSION DRAWING)

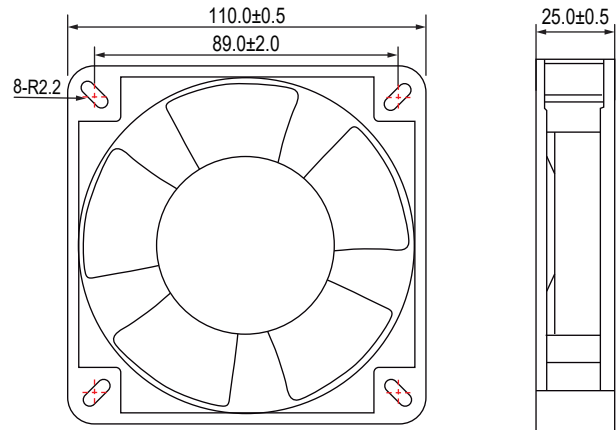

Unit:mm

- * 轴承类型: 滚珠轴承 (Bearing type: 2-ball)
- * 材料 (Material):
框 (Frame): 铝合金 Aluminum Alloy
扇叶 (Impeller): PBT (UL94V-0)
- * 引线 (Lead wire):
UL1430 AWG #22 or equivalent
- * 马达 (Motor): Shaded pole 罩极马达
- * 保护 (Protection): Impedance protection
- * 重量 (Weight): 300g

■ 风压&风量曲线图 P and Q CURVE

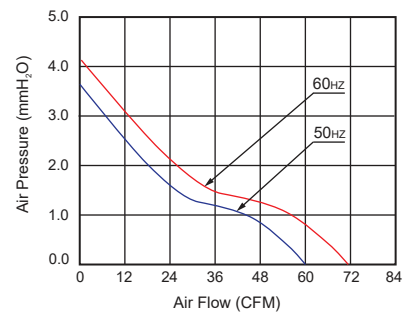

型号 Model	轴承类型 Bearing Type	电压 Voltage	频率 Frequency	电流 Current	功率 Input Power	转速 Speed	风量 Air Flow	风压 Static Pressure	噪音 Noise Level
		VAC	Hz	Amp	Watt	RPM	CFM	MM-H ₂ O	dBA
CC110A10L(T)	2-Ball	100-120	50/60	0.19/0.18	19.0/18.0	2200/2400	60/71	3.6/4.1	36/38
CC110A20L(T)	2-Ball	220-240	50/60	0.09/0.09	18.0/17.0	2200/2400	60/71	3.6/4.1	36/38

- * 以上为额定电压下的常规参数 (All readings are typical values at rated voltage)
- * 规格如有变动不另行通知 (Specifications are subjected to change without prior notice)

AC Axial Fan 120x120x25mm(Ver.A)

■ 尺寸图 (DIMENSION DRAWING)

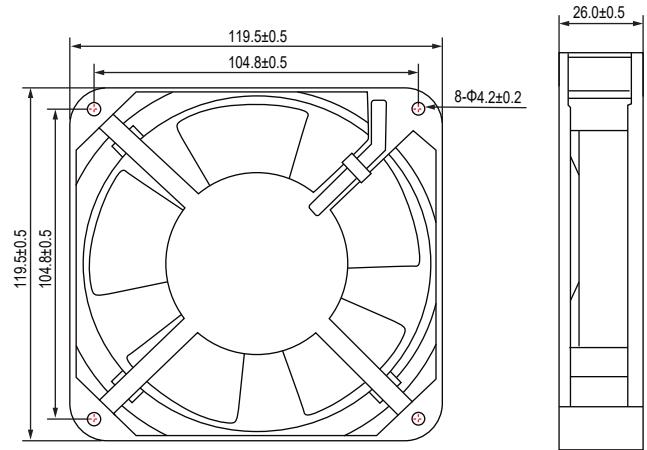

Unit:mm

- * 轴承类型:滚珠轴承 (Bearing type:2-ball)
- * 材料(Material):
框(Frame):铝合金Aluminum Alloy
扇叶(Impeller):PBT(UL94V-0)
- * 引线(Lead wire):
UL1430 AWG #22(Optional)
- * 马达(Motor):罩极马达Shaded pole
- * 保护(Protection): Impedance protection
- * 重量(Weight):320g

■ 风压&风量曲线图 P and Q CURVE

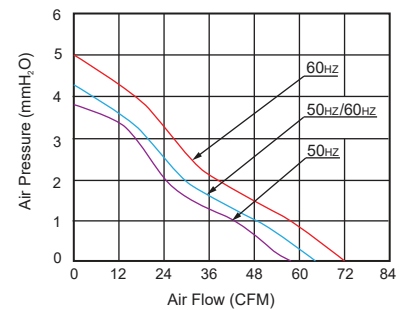

型号 Model	轴承类型 Bearing Type	电压 Voltage	频率 Frequency	电流 Current	功率 Input Power	转速 Speed	风量 Air Flow	风压 Static Pressure	噪音 Noise Level
		VAC	Hz	Amp	Watt	RPM	CFM	MM-H ₂ O	dBA
CC120A10L(T)	2-Ball	100-120	50/60	0.16/0.15	17.0/15.0	2200/2400	58/63	3.8/4.2	35/37
CC120A20L(T)	2-Ball	220-240	50/60	0.07/0.06	17.0/15.0	2200/2400	58/63	3.8/4.2	35/37
CC120A10L(T)	2-Ball	100-120	50/60	0.18/0.14	14.0/11.0	2400/2800	63/72	4.2/5.0	37/40
CC120A20L(T)	2-Ball	220-240	50/60	0.09/0.07	14.0/11.0	2400/2800	63/72	4.2/5.0	37/40

- * 以上为额定电压下的常规参数(All readings are typical values at rated voltage)
- * 规格如有变动不另行通知(Specifications are subjected to change without prior notice)

AC Axial Fan 120x120x25mm(Ver.B)

■ 尺寸图 (DIMENSION DRAWING)

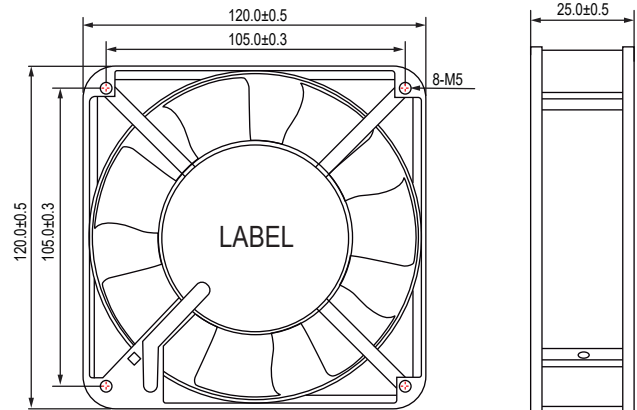

Unit:mm

- * 轴承类型:滚珠轴承 (Bearing type:2-ball)
- * 材料(Material):
框(Frame):铝合金Aluminum Alloy
扇叶(Impeler):PBT(UL94V-0)
- * 引线(Lead wire):
UL1430 AWG #22(Optional)
- * 马达(Motor):罩极马达Shaded pole
- * 保护(Protection): Impedance protection
- * 重量(Weight):320g

■ 风压&风量曲线图 P and Q CURVE

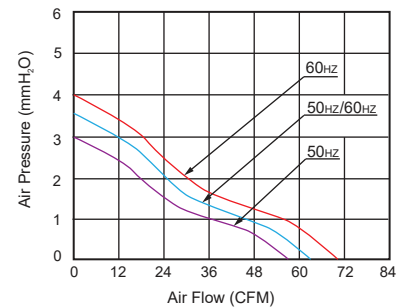

型号 Model	轴承类型 Bearing Type	电压 Voltage	频率 Frequency	电流 Current	功率 Input Power	转速 Speed	风量 Air Flow	风压 Static Pressure	噪音 Noise Level
		VAC	Hz	Amp	Watt	RPM	CFM	MM-H ₂ O	dBA
CC120A10L(T)	2-Ball	100-120	50/60	0.14/0.13	11.0/10.0	2000/2200	58/62	3.0/3.5	36/38
CC120A20L(T)	2-Ball	220-240	50/60	0.07/0.06	11.0/10.0	2000/2200	58/62	3.0/3.5	36/38
CC120A10L(T)	2-Ball	100-120	50/60	0.16/0.15	14.0/13.0	2200/2400	62/70	3.5/4.0	38/40
CC120A20L(T)	2-Ball	220-240	50/60	0.10/0.09	14.0/13.0	2200/2400	62/70	3.5/4.0	38/40

- * 以上为额定电压下的常规参数(All readings are typical values at rated voltage)
- * 规格如有变动不另行通知(Specifications are subjected to change without prior notice)

AC Axial Fan 120x120x38mm(Ver.A)

■ 尺寸图 (DIMENSION DRAWING)

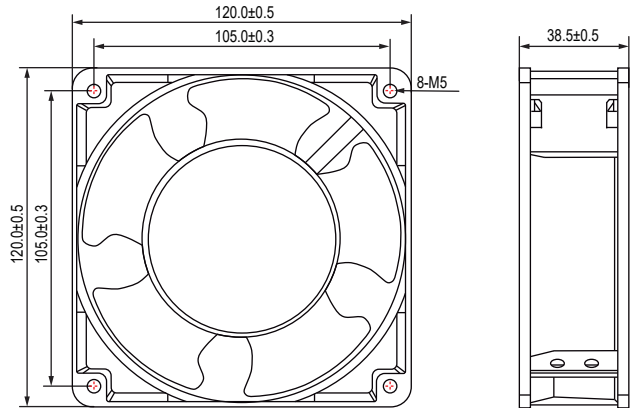

Unit:mm

- * 轴承类型:滚珠轴承 (Bearing type:2-ball)
- * 材料(Material):
框 (Frame):铝合金Aluminum Alloy
扇叶 (Impeller):PBT(UL94V-0)
- * 引线(Lead wire):
UL1430 AWG #22(Optional)
- * 马达(Motor):罩极马达Shaded pole
- * 保护(Protection): Impedance protection
- * 重量(Weight):520g

■ 风压&风量曲线图 P and Q CURVE

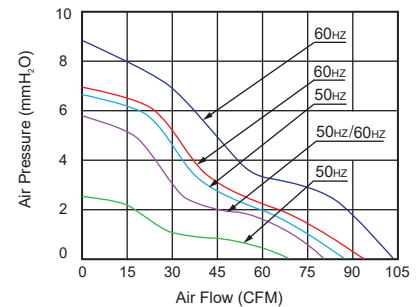

型号 Model	轴承类型 Bearing Type	电压	频率	电流	功率	转速	风量	风压	噪音
		VAC	Hz	Amp	Watt	RPM	CFM	MM-H ₂ O	dBA
CC120B10L(T)	2-Ball	100-120	50/60	0.12/0.10	11/9	1,800/2,500	66/79	2.5/5.8	34/39
CC120B20L(T)	2-Ball	220-240	50/60	0.06/0.05	12/10	1,800/2,500	66/79	2.5/5.8	34/39
CC120B10L(T)	2-Ball	100-120	50/60	0.17/0.13	14/10	2,500/2,800	79/93	5.8/7.1	39/44
CC120B20L(T)	2-Ball	220-240	50/60	0.09/0.07	16/11	2,500/2,800	79/93	5.8/7.1	39/44
CC120B10L(T)	2-Ball	100-120	50/60	0.28/0.21	25/19	2,600/3,000	85/102	6.6/8.6	43/49
CC120B20L(T)	2-Ball	220-240	50/60	0.13/0.09	16/14	2,600/3,000	85/102	6.6/8.6	43/49
CC120B30L(T)	2-Ball	380	50/60	0.06/0.05	16/14	2,600/3,000	85/102	6.6/8.6	43/49

- * 以上为额定电压下的常规参数(All readings are typical values at rated voltage)
- * 规格如有变动不另行通知(Specifications are subjected to change without prior notice)

AC Axial Fan 120x120x38mm(Ver.B)

■ 尺寸图 (DIMENSION DRAWING)

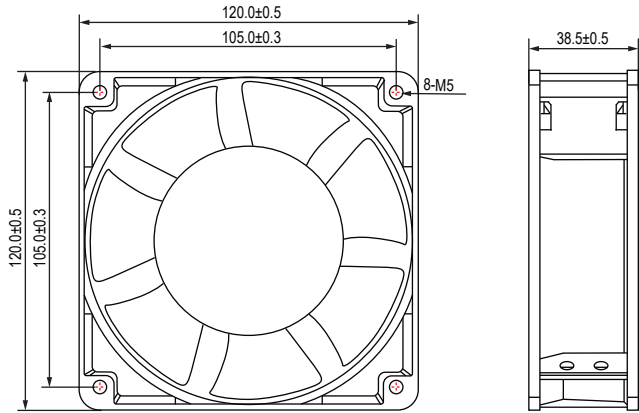

Unit:mm

- * 轴承类型:滚珠轴承 (Bearing type:2-ball)
- * 材料(Material):
框(Frame):铝合金Aluminum Alloy
扇叶(Impeler):PBT(UL94V-0)
- * 引线(Lead wire):
UL1430 AWG #22(Optional)
- * 马达(Motor):罩极马达Shaded pole
- * 保护(Protection): Impedance protection
- * 重量(Weight):540g

■ 风压&风量曲线图 P and Q CURVE

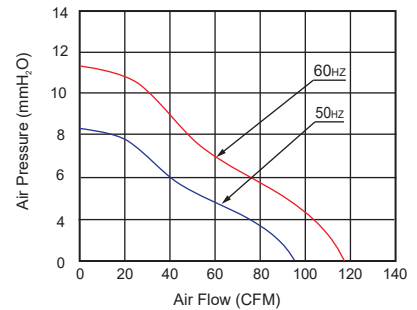

型号 Model	轴承类型 Bearing Type	电压 Voltage	频率 Frequency	电流 Current	功率 Input Power	转速 Speed	风量 Air Flow	风压 Static Pressure	噪音 Noise Level
		VAC	Hz	Amp	Watt	RPM	CFM	MM-H ₂ O	dBA
CC120B10L(T)	2-Ball	100-120	50/60	0.22/0.18	21/18	2,550/2,900	93/115	8.1/11.2	40/45
CC120B20L(T)	2-Ball	220-240	50/60	0.12/0.11	20/19	2,550/2,900	93/115	8.1/11.2	40/45
CC120B30L(T)	2-Ball	380	50/60	0.06	18	2,550	93	8.1	40

- * 以上为额定电压下的常规参数(All readings are typical values at rated voltage)
- * 规格如有变动不另行通知(Specifications are subjected to change without prior notice)

AC Axial Fan 120x120x38mm(Ver.C)

■ 尺寸图 (DIMENSION DRAWING)

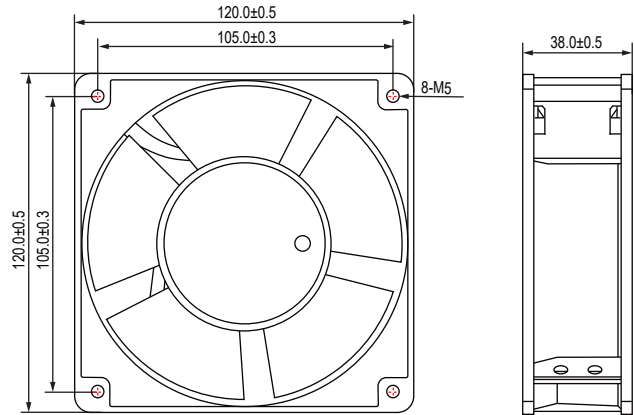

Unit:mm

- * 轴承类型:滚珠轴承 (Bearing type:2-ball)
- * 材料(Material):
框(Frame):铝合金Aluminum Alloy
扇叶(Impeller):铝合金Aluminum Alloy
- * 引线(Lead wire):
UL1430 AWG #22(Optional)
- * 马达(Motor):罩极马达Shaded pole
- * 保护(Protection): Impedance protection
- * 重量(Weight):780g

■ 风压&风量曲线图 P and Q CURVE

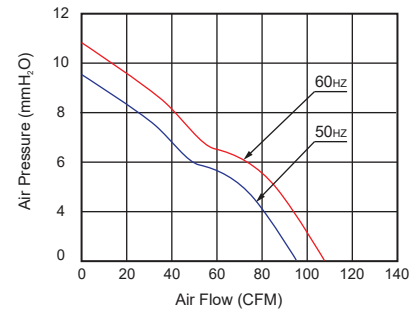

型号 Model	轴承类型 Bearing Type	电压 Voltage	频率 Frequency	电流 Current	功率 Input Power	转速 Speed	风量 Air Flow	风压 Static Pressure	噪音 Noise Level
		VAC	Hz	Amp	Watt	RPM	CFM	MM-H ₂ O	dB(A)
CC120B10L(T)	2-Ball	100-120	50/60	0.24/0.20	21/18	2,700/3,100	93/107	9.4/10.7	45/50
CC120B20L(T)	2-Ball	220-240	50/60	0.12/0.10	21/18	2,700/3,100	93/107	9.4/10.7	45/50

- * 以上为额定电压下的常规参数(All readings are typical values at rated voltage)
- * 规格如有变动不另行通知(Specifications are subjected to change without prior notice)

AC Axial Fan 135x135x38mm

■ 尺寸图 (DIMENSION DRAWING)

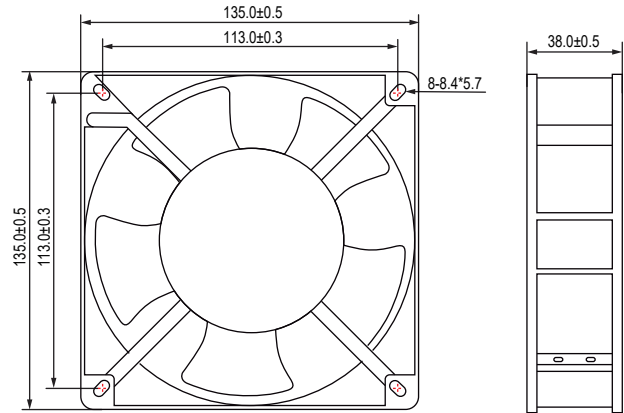

Unit:mm

- * 轴承类型:滚珠轴承 (Bearing type:2-ball)
- * 材料(Material):
框(Frame):铝合金Aluminum Alloy
扇叶(Impeler):PBT(UL94V-0)
- * 引线(Lead wire):
UL1430 AWG #22(Optional)
- * 马达(Motor):罩极马达Shaded pole
- * 保护(Protection): Impedance protection
- * 重量(Weight):900g

■ 风压&风量曲线图 P and Q CURVE

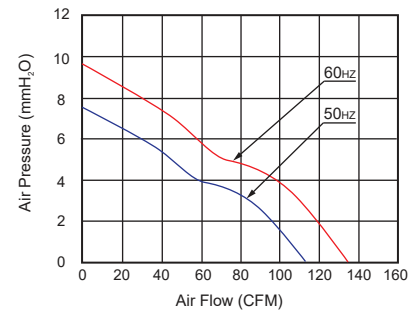

型号 Model	轴承类型 Bearing Type	电压 Voltage	频率 Frequency	电流 Current	功率 Input Power	转速 Speed	风量 Air Flow	风压 Static Pressure	噪音 Noise Level
		VAC	Hz	Amp	Watt	RPM	CFM	MM-H ₂ O	dBA
CC135B10L(T)	2-Ball	100-120	50/60	0.34/0.28	25/19	2,600/3000	113/135	7.4/9.4	46/53
CC135B20L(T)	2-Ball	220-240	50/60	0.18/0.13	23/18	2,600/3000	113/135	7.4/9.4	46/53

- * 以上为额定电压下的常规参数(All readings are typical values at rated voltage)
- * 规格如有变动不另行通知(Specifications are subjected to change without prior notice)

AC Axial Fan 150x150x38mm

■ 尺寸图 (DIMENSION DRAWING)

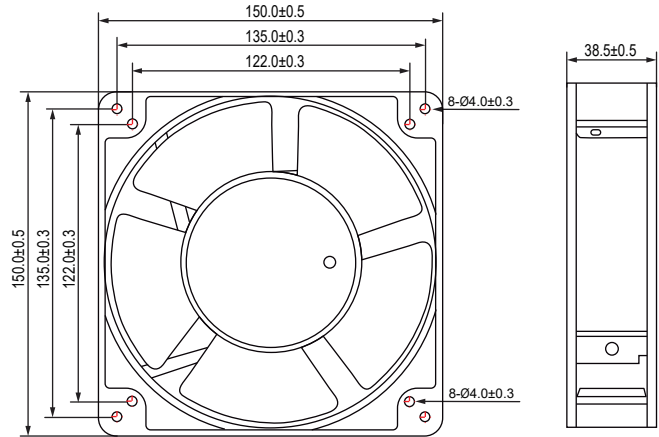

Unit:mm

- * 轴承类型:滚珠轴承 (Bearing type:2-ball)
- * 材料(Material):
框 (Frame):铝合金Aluminum Alloy
扇叶 (Impeller):铝合金Aluminum Alloy
- * 引线(Lead wire):
UL1015 AWG #22(Optional)
- * 马达(Motor):罩极马达Shaded pole
- * 保护(Protection): Impedance protection
- * 重量(Weight):1500g

■ 风压&风量曲线图 P and Q CURVE

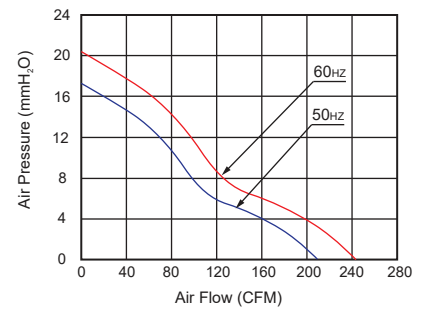

型号 Model	轴承类型 Bearing Type	电压 Voltage	频率 Frequency	电流 Current	功率 Input Power	转速 Speed	风量 Air Flow	风压 Static Pressure	噪音 Noise Level
		VAC	Hz	Amp	Watt	RPM	CFM	MM-H ₂ O	dBA
CC150B10L(T)	2-Ball	100-120	50/60	0.35/0.30	27/25	2,600/2800	210/245	17.3/20.3	52/55
CC150B20L(T)	2-Ball	220-240	50/60	0.17/0.15	27/25	2,600/2800	210/245	17.3/20.3	52/55

- * 以上为额定电压下的常规参数(All readings are typical values at rated voltage)
- * 规格如有变动不另行通知(Specifications are subjected to change without prior notice)

AC Axial Fan 150x150x50mm

■ 尺寸图 (DIMENSION DRAWING)

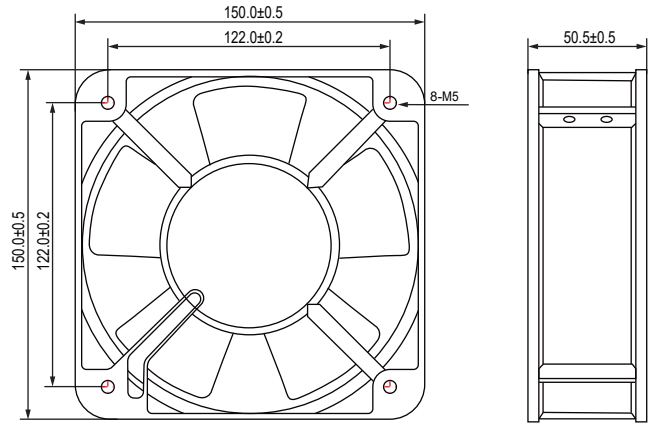

Unit:mm

- * 轴承类型:滚珠轴承 (Bearing type:2-ball)
- * 材料(Material):
框(Frame):铝合金Aluminum Alloy
扇叶(Impeller):PBT(UL94V-0)
- * 引线(Lead wire):
UL1015 AWG #22(Optional)
- * 马达(Motor):罩极马达Shaded pole
- * 保护(Protection): Impedance protection
- * 重量(Weight):860g

■ 风压&风量曲线图 P and Q CURVE

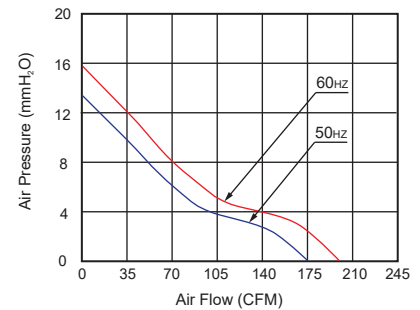

型号 Model	轴承类型 Bearing Type	电压 Voltage	频率 Frequency	电流 Current	功率 Input Power	转速 Speed	风量 Air Flow	风压 Static Pressure	噪音 Noise Level
		VAC	Hz	Amp	Watt	RPM	CFM	MM-H ₂ O	dBA
CC150D10L(T)	2-Ball	100-120	50/60	0.40/0.34	28/36	2,600/2,800	175/195	13.5/15.8	48/52
CC150D20L(T)	2-Ball	220-240	50/60	0.23/0.27	34/28	2,600/2,800	175/195	13.5/15.8	48/52

- * 以上为额定电压下的常规参数(All readings are typical values at rated voltage)
- * 规格如有变动不另行通知(Specifications are subjected to change without prior notice)

AC Axial Fan 172x150x38mm(Ver.A)

■ 尺寸图 (DIMENSION DRAWING)

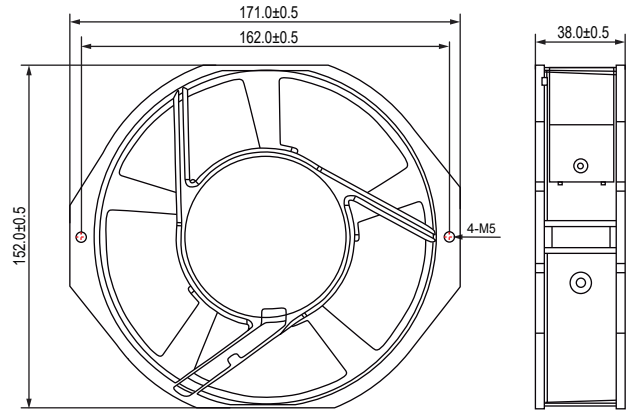

Unit:mm

- * 轴承类型:滚珠轴承 (Bearing type:2-ball)
- * 材料(Material):
框(Frame):铝合金Aluminum Alloy
扇叶(Impeller):PBT(UL94V-0)
- * 引线(Lead wire):
UL1015 AWG #22(Optional)
- * 马达(Motor):Capacitor-start induction motor
- * 保护(Protection): Impedance protection
- * 重量(Weight):760g

■ 风压&风量曲线图 P and Q CURVE

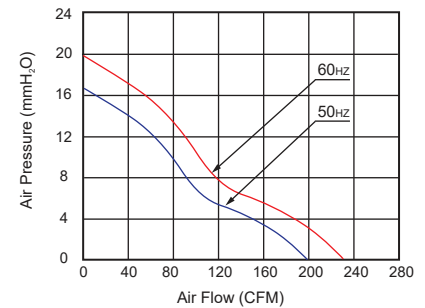

型号 Model	轴承类型 Bearing Type	电压 Voltage	频率 Frequency	电流 Current	功率 Input Power	转速 Speed	风量 Air Flow	风压 Static Pressure	噪音 Noise Level
		VAC	Hz	Amp	Watt	RPM	CFM	MM-H ₂ O	dBA
CC170B10L(T)	2-Ball	100-120	50/60	0.27/0.24	31/25	2,850/3,300	195/230	16.5/19.8	52/55
CC170B20L(T)	2-Ball	220-240	50/60	0.14/0.11	31/25	2,850/3,300	195/230	16.5/19.8	52/55

- * 以上为额定电压下的常规参数(All readings are typical values at rated voltage)
- * 规格如有变动不另行通知(Specifications are subjected to change without prior notice)

AC Axial Fan 172x150x38mm(Ver.B)

■ 尺寸图 (DIMENSION DRAWING)

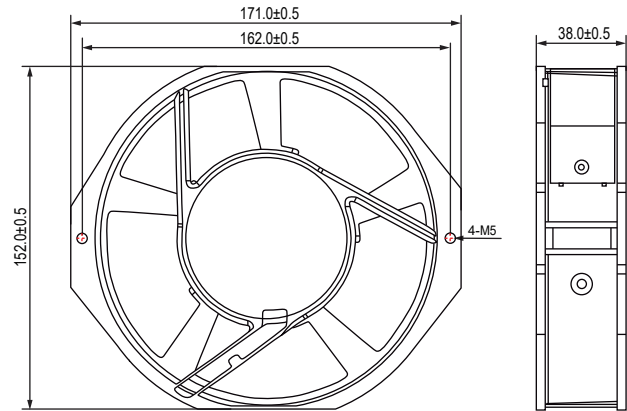

Unit:mm

- * 轴承类型:滚珠轴承 (Bearing type:2-ball)
- * 材料(Material):
框 (Frame):铝合金Aluminum Alloy
扇叶 (Impeller):PBT(UL94V-0)
- * 引线(Lead wire):
UL1015 AWG #22(Optional)
- * 马达(Motor):罩极马达Shaded pole
- * 保护(Protection): Impedance protection
- * 重量(Weight):760g

■ 风压&风量曲线图 P and Q CURVE

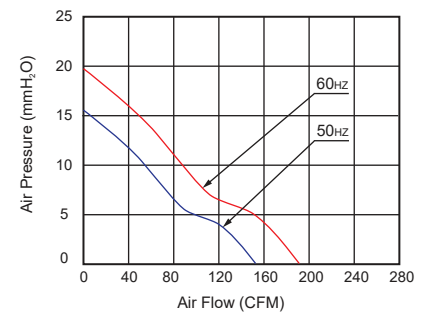

型号 Model	轴承类型 Bearing Type	电压 Voltage	频率 Frequency	电流 Current	功率 Input Power	转速 Speed	风量 Air Flow	风压 Static Pressure	噪音 Noise Level
		VAC	Hz	Amp	Watt	RPM	CFM	MM-H ₂ O	dBA
CC170B10L(T)	2-Ball	100-120	50/60	0.27/0.24	31/25	2,400/2,700	150/185	16.5/19.8	52/55
CC170B20L(T)	2-Ball	220-240	50/60	0.14/0.11	31/25	2,400/2,700	150/185	16.5/19.8	52/55

- * 以上为额定电压下的常规参数(All readings are typical values at rated voltage)
- * 规格如有变动不另行通知(Specifications are subjected to change without prior notice)

AC Axial Fan 172x150x51mm(Ver.A)

■ 尺寸图 (DIMENSION DRAWING)

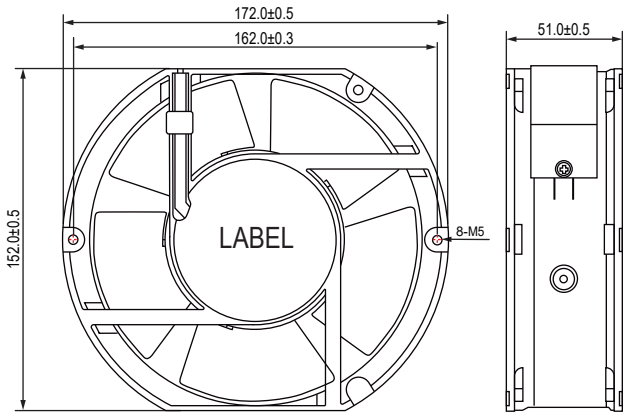

Unit:mm

- * 轴承类型: 滚珠轴承 (Bearing type: 2-ball)
- * 材料(Material):
框(Frame): 铝合金 Aluminum Alloy
扇叶(Impeller): PBT(UL94V-0)
- * 引线(Lead wire):
UL1015 AWG #22(Optional)
- * 马达(Motor): 罩极马达 Shaded pole
- * 保护(Protection): Impedance protection
- * 重量(Weight): 880g

■ 风压&风量曲线图 P and Q CURVE

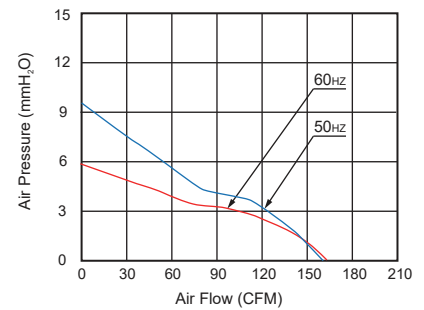

型号 Model	轴承类型 Bearing Type	电压 Voltage	频率 Frequency	电流 Current	功率 Input Power	转速 Speed	风量 Air Flow	风压 Static Pressure	噪音 Noise Level
		VAC	Hz	Amp	Watt	RPM	CFM	MM-H ₂ O	dBA
CC170D10L(T)	2-Ball	100-120	50/60	0.40/0.34	28/36	2,650/2,750	163/165	9.4/5.9	53/54
CC170D20L(T)	2-Ball	220-240	50/60	0.20/0.18	35/36	2,650/2,750	163/165	9.4/5.9	53/54

- * 以上为额定电压下的常规参数(All readings are typical values at rated voltage)
- * 规格如有变动不另行通知(Specifications are subjected to change without prior notice)

AC Axial Fan 172x150x51mm(Ver.B)

■ 尺寸图 (DIMENSION DRAWING)

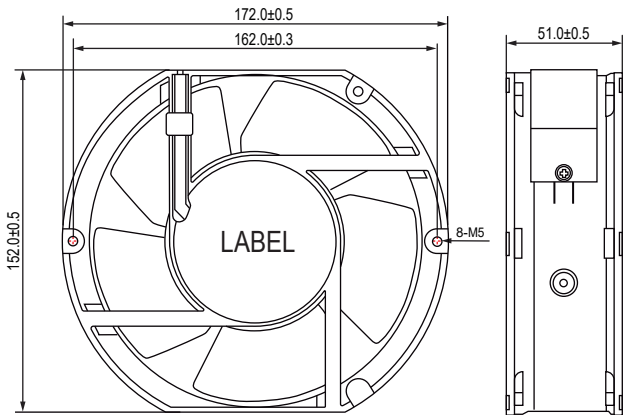

Unit:mm

- * 轴承类型:滚珠轴承 (Bearing type:2-ball)
- * 材料(Material):
框(Frame):铝合金Aluminum Alloy
扇叶(Impeller):铁Iron
- * 引线(Lead wire):
UL1015 AWG #22(Optional)
- * 马达(Motor):罩极马达Shaded pole
- * 保护(Protection): Impedance protection
- * 重量(Weight):1000g

■ 风压&风量曲线图 P and Q CURVE

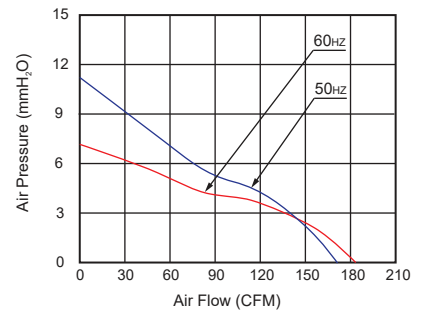

型号 Model	轴承类型 Bearing Type	电压 Voltage	频率 Frequency	电流 Current	功率 Input Power	转速 Speed	风量 Air Flow	风压 Static Pressure	噪音 Noise Level
		VAC	Hz	Amp	Watt	RPM	CFM	MM-H ₂ O	dBA
CC170D10L(T)	2-Ball	100-120	50/60	0.50/0.47	28/36	2,600/2,800	169/182	10.9/7.1	50/52
CC170D20L(T)	2-Ball	220-240	50/60	0.28/0.25	34/28	2,600/2,800	169/182	10.9/7.1	50/52

- * 以上为额定电压下的常规参数(All readings are typical values at rated voltage)
- * 规格如有变动不另行通知(Specifications are subjected to change without prior notice)

AC Axial Fan 172x150x51mm(Ver.C)

■ 尺寸图 (DIMENSION DRAWING)

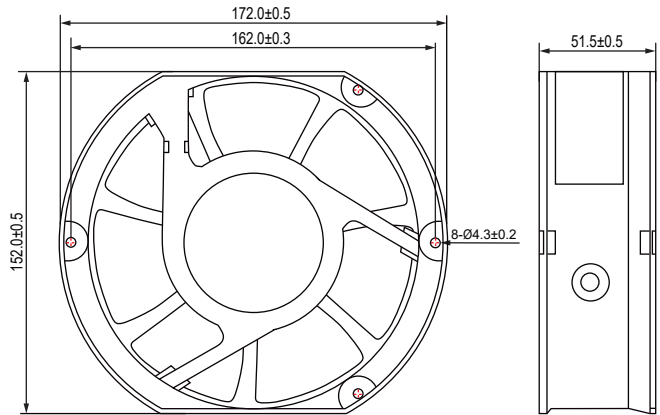

Unit:mm

- * 轴承类型:滚珠轴承 (Bearing type:2-ball)
- * 材料(Material):
框(Frame):铝合金Aluminum Alloy
扇叶(Impeler):PBT(UL94V-0)
- * 引线(Lead wire):
UL 1015 AWG #22(Optional)
- * 马达(Motor):罩极马达Shaded pole
- * 保护(Protection): Impedance protection
- * 重量(Weight):880g

■ 风压&风量曲线图 P and Q CURVE

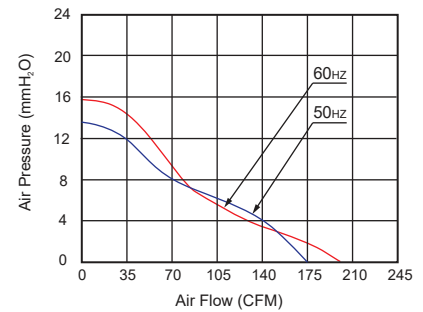

型号 Model	轴承类型 Bearing Type	电压 Voltage	频率 Frequency	电流 Current	功率 Input Power	转速 Speed	风量 Air Flow	风压 Static Pressure	噪音 Noise Level
		VAC	Hz	Amp	Watt	RPM	CFM	MM-H ₂ O	dBA
CC170D10L(T)	2-Ball	100-120	50/60	0.40/0.34	28/36	2,600/2,800	175/195	13.5/15.7	48/52
CC170D20L(T)	2-Ball	220-240	50/60	0.23/0.27	34/28	2,600/2,800	175/195	13.5/15.7	48/52
CC170D30L(T)	2-Ball	380V	50/60	0.21/0.26	32/28	2,600/2,800	175/195	13.5/15.7	48/52

- * 以上为额定电压下的常规参数(All readings are typical values at rated voltage)
- * 规格如有变动不另行通知(Specifications are subjected to change without prior notice)

AC Axial Fan 172x150x55mm

■ 尺寸图 (DIMENSION DRAWING)

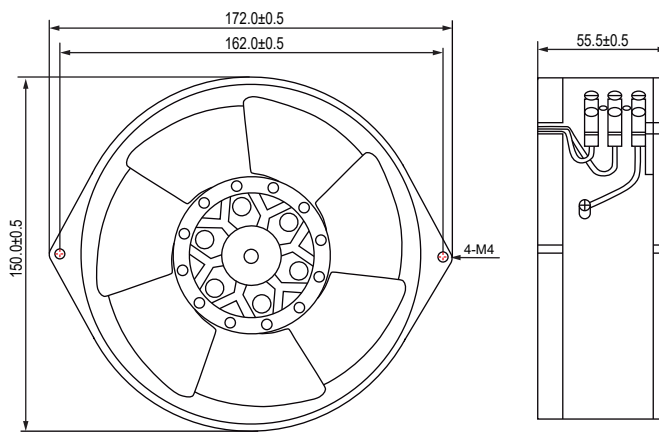

Unit:mm

- * 轴承类型:滚珠轴承 (Bearing type:2-ball)
- * 材料(Material):
框(Frame):铝合金Aluminum Alloy
扇叶(Impeller):铁Iron
- * 引线(Lead wire):
UL1015 AWG #22(Optional)
- * 马达(Motor):罩极马达Shaded pole
- * 保护(Protection): Impedance protection
- * 重量(Weight):880g

■ 风压&风量曲线图 P and Q CURVE

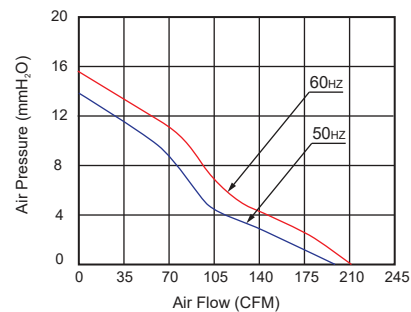

型号 Model	轴承类型 Bearing Type	电压 Voltage	频率 Frequency	电流 Current	功率 Input Power	转速 Speed	风量 Air Flow	风压 Static Pressure	噪音 Noise Level
		VAC	Hz	Amp	Watt	RPM	CFM	MM-H ₂ O	dBA
CC170E10L(T)	2-Ball	100-120	50/60	0.40/0.34	28/36	2,600/2,800	190/210	14.2/15.7	49/53
CC170E20L(T)	2-Ball	220-240	50/60	0.23/0.27	34/28	2,600/2,800	190/210	14.2/15.7	49/53

- * 以上为额定电压下的常规参数(All readings are typical values at rated voltage)
- * 规格如有变动不另行通知(Specifications are subjected to change without prior notice)

AC Axial Fan 180x180x60mm

■ 尺寸图 (DIMENSION DRAWING)

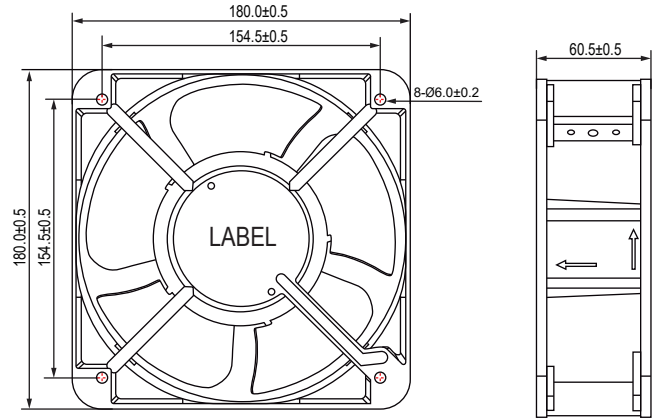

Unit:mm

- * 轴承类型:滚珠轴承 (Bearing type:2-ball)
- * 材料(Material):
框 (Frame):铝合金Aluminum Alloy
扇叶 (Impeller):PBT(UL94V-0)
- * 引线(Lead wire):
UL1015 AWG #22(Optional)
- * 马达(Motor):罩极马达Shaded pole
- * 保护(Protection): Impedance protection
- * 重量(Weight):880g

■ 风压&风量曲线图 P and Q CURVE

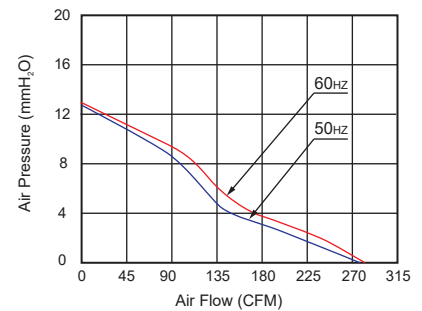

型号 Model	轴承类型 Bearing Type	电压 Voltage	频率 Frequency	电流 Current	功率 Input Power	转速 Speed	风量 Air Flow	风压 Static Pressure	噪音 Noise Level
		VAC	Hz	Amp	Watt	RPM	CFM	MM-H ₂ O	dBA
CC180F10L(T)	2-Ball	100-120	60	0.69	56	2,600	280	13.2	59
CC180F20L(T)	2-Ball	220-240	50	0.30	45	2,600	280	13.2	59
CC180F30L(T)	2-Ball	380	50	0.16	42	2,550	275	13.1	59

- * 以上为额定电压下的常规参数(All readings are typical values at rated voltage)
- * 规格如有变动不另行通知(Specifications are subjected to change without prior notice)

AC Axial Fan 200x200x60mm

■ 尺寸图 (DIMENSION DRAWING)

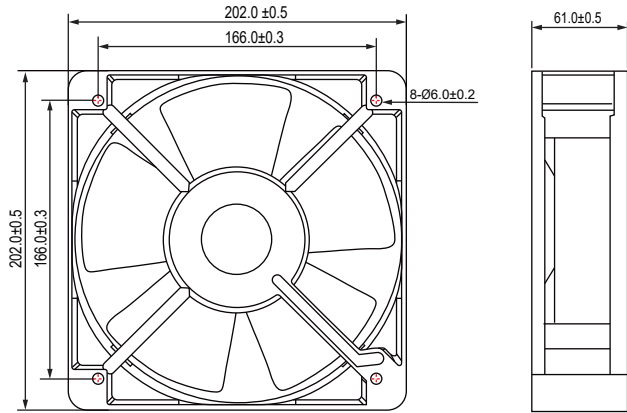

Unit:mm

- * 轴承类型: 滚珠轴承 (Bearing type: 2-ball)
- * 材料 (Material):
框 (Frame): 铝合金 Aluminum Alloy
扇叶 (Impeller): PBT (UL94V-0)
- * 引线 (Lead wire):
UL1015 AWG #22 (Optional)
- * 马达 (Motor): 罩极马达 Shaded pole
- * 保护 (Protection): Impedance protection
- * 重量 (Weight): 1430g

■ 风压&风量曲线图 P and Q CURVE

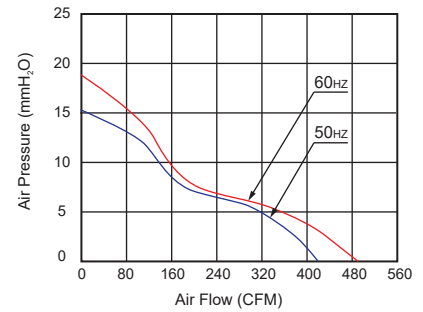

型号 Model	轴承类型 Bearing Type	电压 Voltage	频率 Frequency	电流 Current	功率 Input Power	转速 Speed	风量 Air Flow	风压 Static Pressure	噪音 Noise Level
		VAC	Hz	Amp	Watt	RPM	CFM	MM-H ₂ O	dBA
CC200F10L(T)	2-Ball	100-120	50/60	0.86/0.80	65/60	2,500/2,800	420/490	15.3/18.3	60/65
CC200F20L(T)	2-Ball	220-240	50/60	0.45/0.40	65/60	2,500/2,800	420/490	15.3/18.3	60/65

- * 以上为额定电压下的常规参数 (All readings are typical values at rated voltage)
- * 规格如有变动不另行通知 (Specifications are subjected to change without prior notice)

AC Axial Fan 205x205x72mm(Ver.A)

■ 尺寸图 (DIMENSION DRAWING)

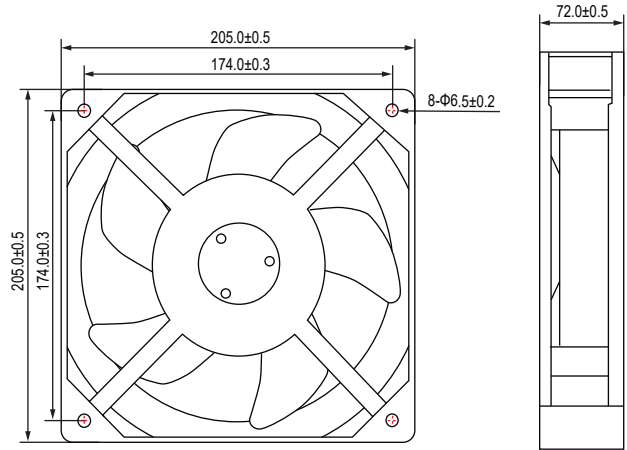

Unit:mm

- * 轴承类型:滚珠轴承 (Bearing type:2-ball)
- * 材料(Material):
框 (Frame):铝合金Aluminum Alloy
扇叶 (Impeller):PBT(UL94V-0)
- * 引线(Lead wire):
UL1015 AWG #22(Optional)
- * 马达(Motor):Capacitor-start induction motor
- * 保护(Protection): Impedance protection
- * 重量(Weight):2100g

■ 风压&风量曲线图 P and Q CURVE

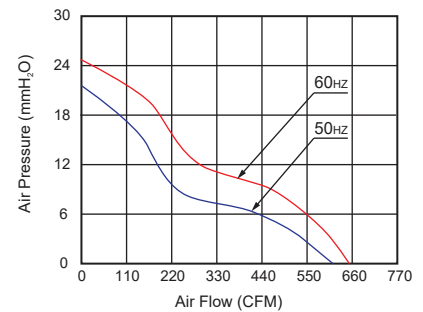

型号 Model	轴承类型 Bearing Type	电压 Voltage	频率 Frequency	电流 Current	功率 Input Power	转速 Speed	风量 Air Flow	风压 Static Pressure	噪音 Noise Level
		VAC	Hz	Amp	Watt	RPM	CFM	MM-H ₂ O	dBA
CC205Z10L(T)	2-Ball	100-120	50/60	0.52/0.66	65/100	2,850/3,250	600/655	21.6/24.9	67/71
CC205Z20L(T)	2-Ball	220-240	50/60	0.31/0.45	62/95	2,850/3,250	600/655	21.6/24.9	67/71
CC205Z30L(T)	2-Ball	380	50/60	0.18/0.26	68/98	2,850/3,250	600/655	21.6/24.9	67/71

- * 以上为额定电压下的常规参数(All readings are typical values at rated voltage)
- * 规格如有变动不另行通知(Specifications are subjected to change without prior notice)

AC Axial Fan 205x205x72mm(Ver.B)

■ 尺寸图 (DIMENSION DRAWING)

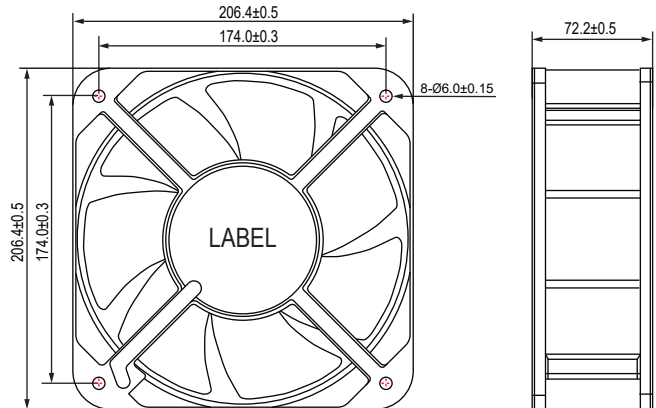

Unit:mm

- * 轴承类型:滚珠轴承 (Bearing type:2-ball)
- * 材料(Material):
框 (Frame):铝合金Aluminum Alloy
扇叶 (Impeller):PBT(UL94V-0)
- * 引线(Lead wire):
UL1015 AWG #22(Optional)
- * 马达(Motor):Capacitor-start induction motor
- * 保护(Protection): Impedance protection
- * 重量(Weight):2300g

■ 风压&风量曲线图 P and Q CURVE

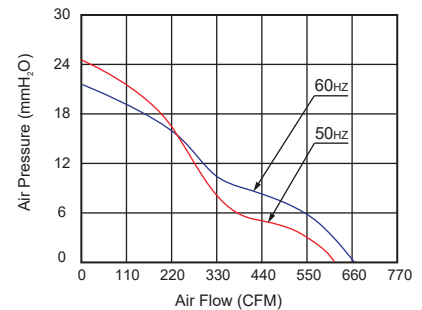

型号 Model	轴承类型 Bearing Type	电压 Voltage	频率 Frequency	电流 Current	功率 Input Power	转速 Speed	风量 Air Flow	风压 Static Pressure	噪音 Noise Level
		VAC	Hz	Amp	Watt	RPM	CFM	MM-H ₂ O	dB(A)
CC205Z10L(T)	2-Ball	100-120	50/60	0.62/0.88	70/100	2,800/3,200	600/665	24.4/21.6	67/71
CC205Z20L(T)	2-Ball	220-240	50/60	0.32/0.45	70/100	2,800/3,200	600/665	24.4/21.6	67/71

- * 以上为额定电压下的常规参数(All readings are typical values at rated voltage)
- * 规格如有变动不另行通知(Specifications are subjected to change without prior notice)

AC Axial Fan Φ220x60mm

■ 尺寸图 (DIMENSION DRAWING)

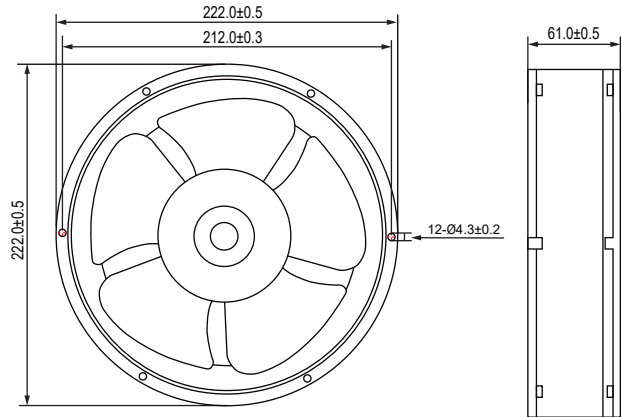

Unit:mm

- * 轴承类型:滚珠轴承 (Bearing type:2-ball)
- * 材料(Material):
框 (Frame):铝合金Aluminum Alloy
扇叶 (Impeller):PBT(UL94V-0)
- * 引线(Lead wire):
UL1015 AWG #22(Optional)
- * 马达(Motor):罩极马达Shaded pole
- * 保护(Protection): Impedance protection
- * 重量(Weight):1450g

■ 风压&风量曲线图 P and Q CURVE

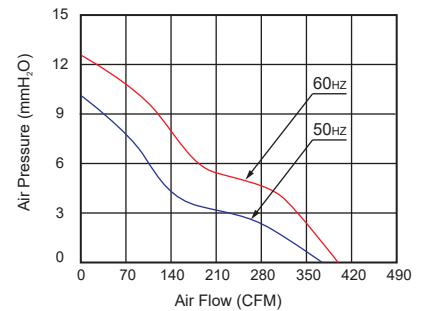

型号 Model	轴承类型 Bearing Type	电压 Voltage	频率 Frequency	电流 Current	功率 Input Power	转速 Speed	风量 Air Flow	风压 Static Pressure	噪音 Noise Level
		VAC	Hz	Amp	Watt	RPM	CFM	MM-H ₂ O	dBA
CC220F10L(T)	2-Ball	100-120	50/60	0.80/0.40	60/56	2,400/2,500	372/388	10.2/12.7	50/54
CC220F20L(T)	2-Ball	220-240	50/60	0.60/0.30	58/49	2,400/2,500	372/388	10.2/12.7	50/54

- * 以上为额定电压下的常规参数(All readings are typical values at rated voltage)
- * 规格如有变动不另行通知(Specifications are subjected to change without prior notice)

AC Axial Fan $\Phi 220 \times 80 \text{mm}$

■ 尺寸图 (DIMENSION DRAWING)

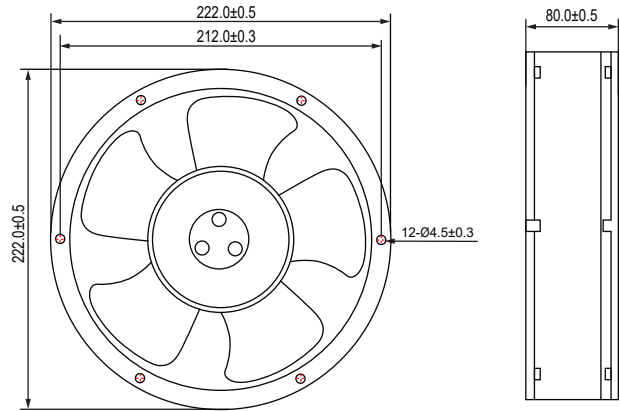

Unit:mm

- * 轴承类型: 滚珠轴承 (Bearing type: 2-ball)
- * 材料 (Material):
框 (Frame): 铝合金 Aluminum Alloy
扇叶 (Impeller): PBT (UL94V-0)
- * 引线 (Lead wire):
UL1015 AWG #22 (Optional)
- * 马达 (Motor): Capacitor-start induction motor
- * 保护 (Protection): Impedance protection
- * 重量 (Weight): 1600g

■ 风压&风量曲线图 P and Q CURVE

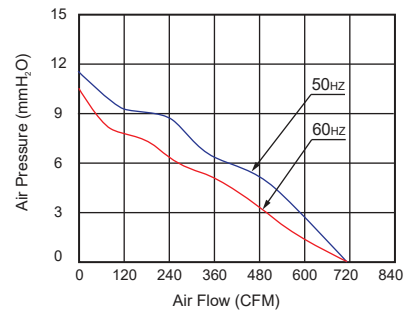

型号 Model	轴承类型 Bearing Type	电压 Voltage	频率 Frequency	电流 Current	功率 Input Power	转速 Speed	风量 Air Flow	风压 Static Pressure	噪音 Noise Level
		VAC	Hz	Amp	Watt	RPM	CFM	MM-H ₂ O	dBA
CC220H10L(T)	2-Ball	100-120	50/60	0.52/0.60	53/67	2,500/2,600	710/710	11.5/10.9	60/60
CC220H20L(T)	2-Ball	220-240	50/60	0.23/0.30	49/64	2,500/2,600	710/710	11.5/10.9	60/60

- * 以上为额定电压下的常规参数 (All readings are typical values at rated voltage)
- * 规格如有变动不另行通知 (Specifications are subjected to change without prior notice)

AC Axial Fan 225x225x80mm

■ 尺寸图 (DIMENSION DRAWING)

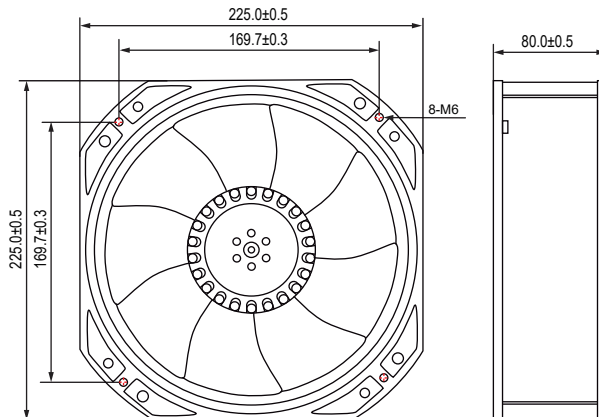

Unit:mm

- * 轴承类型:滚珠轴承 (Bearing type:2-ball)
- * 材料(Material):
框(Frame):铝合金Aluminum Alloy
扇叶(Impeler):铁Iron
- * 引线(Lead wire):
UL1015 AWG #22(Optional)
- * 马达(Motor):Capacitor-start induction motor
- * 保护(Protection): Impedance protection
- * 重量(Weight):2278g

■ 风压&风量曲线图 P and Q CURVE

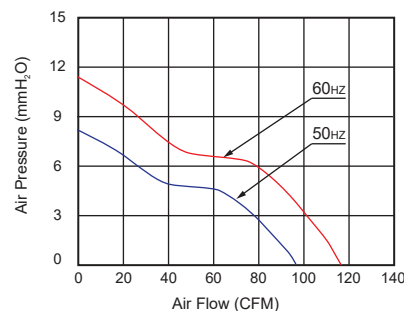

型号 Model	轴承类型 Bearing Type	电压 Voltage	频率 Frequency	电流 Current	功率 Input Power	转速 Speed	风量 Air Flow	风压 Static Pressure	噪音 Noise Level
		VAC	Hz	Amp	Watt	RPM	CFM	MM-H ₂ O	dBA
CC225H10L(T)	2-Ball	100-120	50/60	0.22/0.18	21/18	2,550/2,900	93/115	8.2/11.2	40/45
CC225H20L(T)	2-Ball	220-240	50/60	0.12/0.11	20/19	2,550/2,900	93/115	8.2/11.2	40/45
CC225H30L(T)	2-Ball	380	50	0.06	18	2,550	93	8.2	40

- * 以上为额定电压下的常规参数(All readings are typical values at rated voltage)
- * 规格如有变动不另行通知(Specifications are subjected to change without prior notice)

AC Axial Fan $\Phi 254 \times 89 \text{mm}$

■ 尺寸图 (DIMENSION DRAWING)

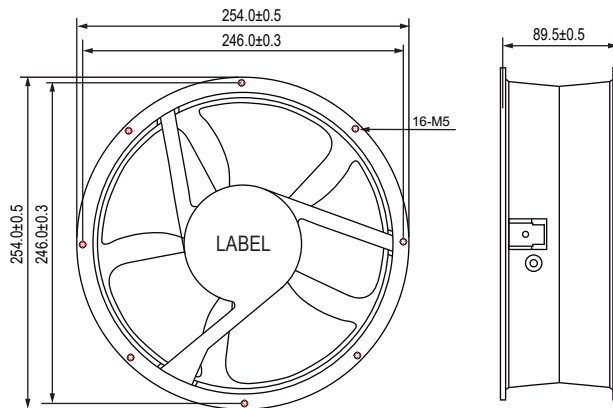

Unit:mm

- * 轴承类型:滚珠轴承 (Bearing type:2-ball)
- * 材料(Material):
框(Frame):铝合金Aluminum Alloy
扇叶(Impeller):PBT(UL94V-0)
- * 引线(Lead wire):
UL1015 AWG #22(Optional)
- * 马达(Motor):Capacitor-start induction motor
- * 保护(Protection): Impedance protection
- * 重量(Weight):2200g

■ 风压&风量曲线图 P and Q CURVE

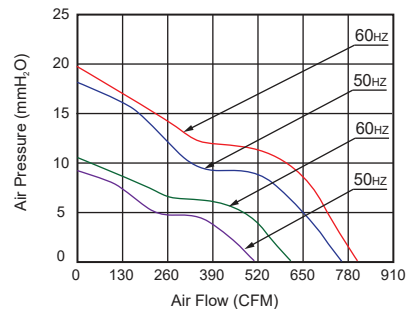

型号 Model	轴承类型 Bearing Type	电压 Voltage	频率 Frequency	电流 Current	功率 Input Power	转速 Speed	风量 Air Flow	风压 Static Pressure	噪音 Noise Level
		VAC	Hz	Amp	Watt	RPM	CFM	MM-H ₂ O	dBA
CC254K10L(T)	2-Ball	100-120	50/60	0.36/0.45	36/43	1,450/1,850	510/600	8.2/10.4	52/54
CC254K20L(T)	2-Ball	220-240	50/60	0.18/0.22	38/45	1,450/1,850	510/600	8.2/10.4	52/54
CC254K10L(T)	2-Ball	100-120	50/60	1.00/0.93	110/125	2,500/2,700	760/800	17.8/19.8	63/65
CC254K20L(T)	2-Ball	220-240	50/60	0.45/0.60	100/125	2,500/2,700	760/800	17.8/19.8	63/65

- * 以上为额定电压下的常规参数(All readings are typical values at rated voltage)
- * 规格如有变动不另行通知(Specifications are subjected to change without prior notice)

AC Axial Fan 280x280x80mm

■ 尺寸图 (DIMENSION DRAWING)

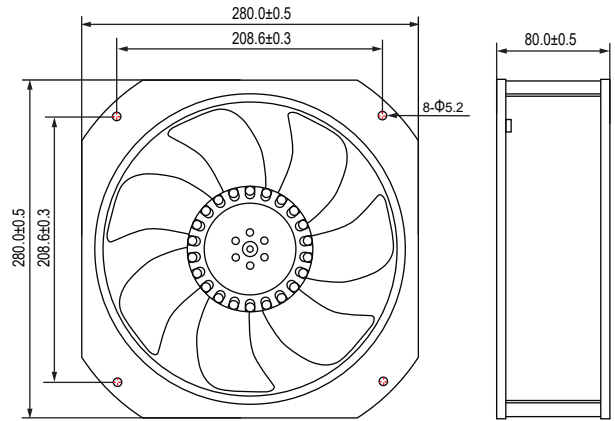

Unit:mm

- * 轴承类型:滚珠轴承 (Bearing type:2-ball)
- * 材料(Material):
框 (Frame):铝合金Aluminum Alloy
扇叶 (Impeller):铁Iron
- * 引线(Lead wire):
UL1015 AWG #22(Optional)
- * 马达(Motor):Capacitor-start induction motor
- * 保护(Protection): Impedance protection
- * 重量(Weight):2800g

■ 风压&风量曲线图 P and Q CURVE

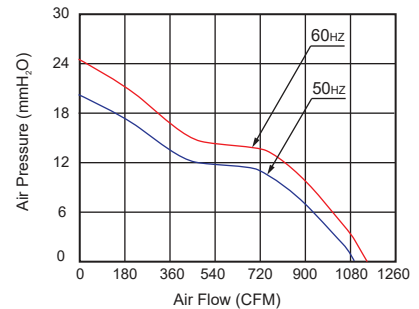

型号 Model	轴承类型 Bearing Type	电压 Voltage	频率 Frequency	电流 Current	功率 Input Power	转速 Speed	风量 Air Flow	风压 Static Pressure	噪音 Noise Level
		VAC	Hz	Amp	Watt	RPM	CFM	MM-H ₂ O	dB(A)
CC280H10L(T)	2-Ball	100-120	50/60	1.10/1.60	120/160	2,600/2,850	1090/1130	20.6/24.2	65/68
CC280H20L(T)	2-Ball	220-240	50/60	0.60/0.84	120/160	2,600/2,850	1090/1130	20.6/24.2	65/68

- * 以上为额定电压下的常规参数(All readings are typical values at rated voltage)
- * 规格如有变动不另行通知(Specifications are subjected to change without prior notice)