

COOLCOX[®]

东莞市奇凌电子科技有限公司
COOLCOX LIMITED

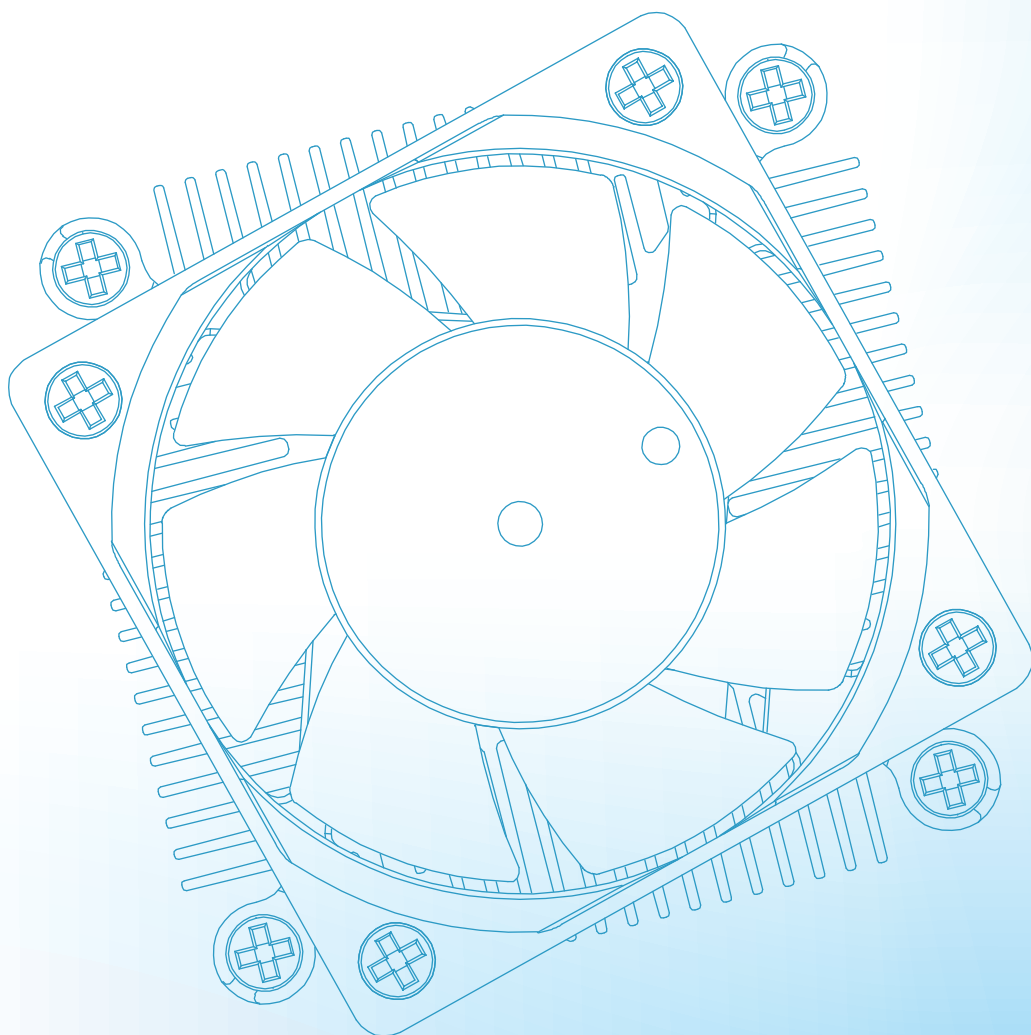

公司简介

奇凌电子创立于2008年,致力于散热产品的研发与生产,是具有“自主品牌和知识产权”的高新科技企业。

研发制造基地位于东莞市望牛墩镇,厂房面积16,000平方米,员工700余人。公司已通过ISO9001、ISO14001、IATF16949、QC080000管理体系认证,产品符合UL、TUV、CE、CQC等安规认证。

公司拥有先进的自动化设备和一流的制造能力,以及严格的品质管理体系,持续为全球客户提供高性能的轴流风扇、鼓风机、散热器、电机等产品,广泛应用于计算机、网络设备、家用电器、医疗设备、安防产品、自控系统、3D打印机、投影仪、新能源等领域。

公司坚持技术创新和品质保证,以全面高效的散热产品和解决方案,为客户实现价值增长。



■ 一般规格 (General Specifications)

- * 风扇轴承类型: 液压轴承
(Fan bearing type: Hydraulic)
- * 风扇材料 (Material):
扇叶 (Impeller): PBT
框 (Housing): PBT & SECC
- * 散热器材质: 铝
(Heatsink: Aluminium)
- * 引线 (Lead wire):
UL1571 AWG #28 or equivalent
红色线正级 Red Wire Positive (+)
黑色线负级 Black Wire Negative (-)
绿色线FG信号 Green Wire Signal (FG)
蓝色线PWM功能 Blue Wire (PWM)
- * 风扇功能 (Fan Functions): FG+PWM
- * 重量 (Weight): 211g



■ 尺寸图 (Dimension Drawing)

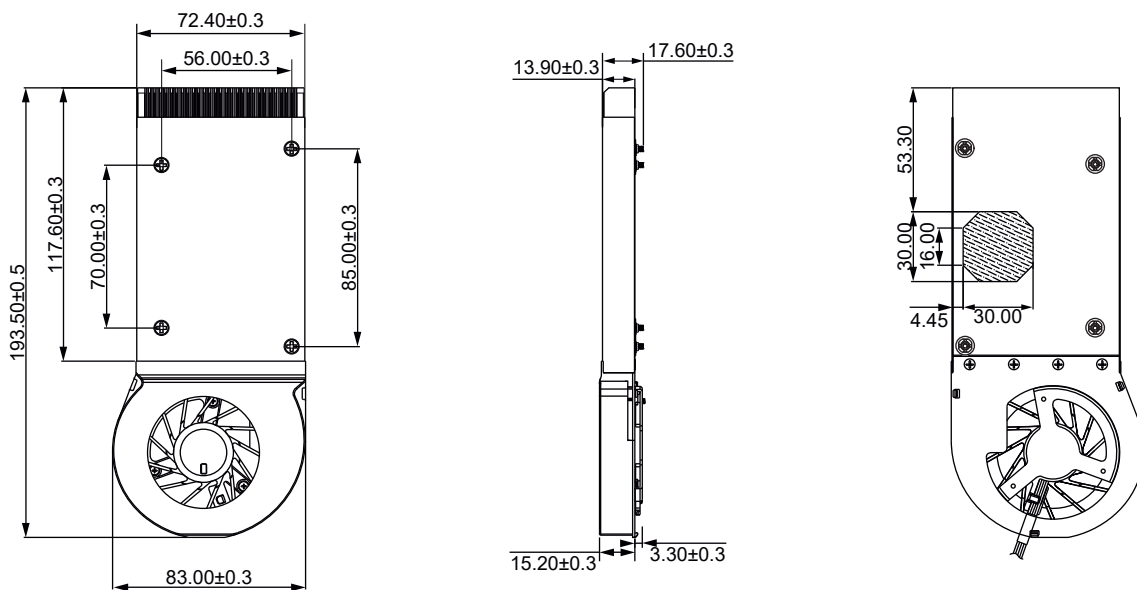

■ 风扇参数 (Fan Parameters)

型号 Model	轴承类型 Bearing Type	电压 Rated Voltage	电压范围 Operation Voltage	电流 Current	功率 Input Power	转速 Speed	风量 Air Flow	风压 Static Pressure	噪音 Noise Level
		VDC	VDC	Amp	Watt	RPM	CFM	MM-H ₂ O	dB-A
CM-EH41A	Hydraulic	5V	4.5~5.5	0.35	1.75	3,600±10%	3.86	3.73	38.5

- * 风扇功能可选择 (Function is optional)
- * 噪音值为在无响室测试得到的结果, 测试距离1米 (Noise is measured in anechoic chamber, one meter from intake side)
- * 以上为额定电压下的常规参数 (All readings are typical values at rated voltage)
- * 规格如有变动不另行通知 (Specifications are subjected to change without prior notice)

■ 一般规格 (General Specifications)

- * 风扇轴承类型: 液压轴承
(Fan bearing type: Hydraulic)
- * 风扇材料(Material):
扇叶(Impeller): PBT
框(Housing): PBT & SECC
- * 散热器材质: 铝
(Heatsink: Aluminium)
- * 引线(Lead wire):
UL1571 AWG #28 or equivalent
红色线正级 Red Wire Positive (+)
黑色线负级 Black Wire Negative (-)
绿色线FG信号 Green Wire Signal (FG)
蓝色线PWM功能 Blue Wire (PWM)
- * 风扇功能(Fan Functions): FG+PWM
- * 重量(Weight): 210g



■ 尺寸图 (Dimension Drawing)

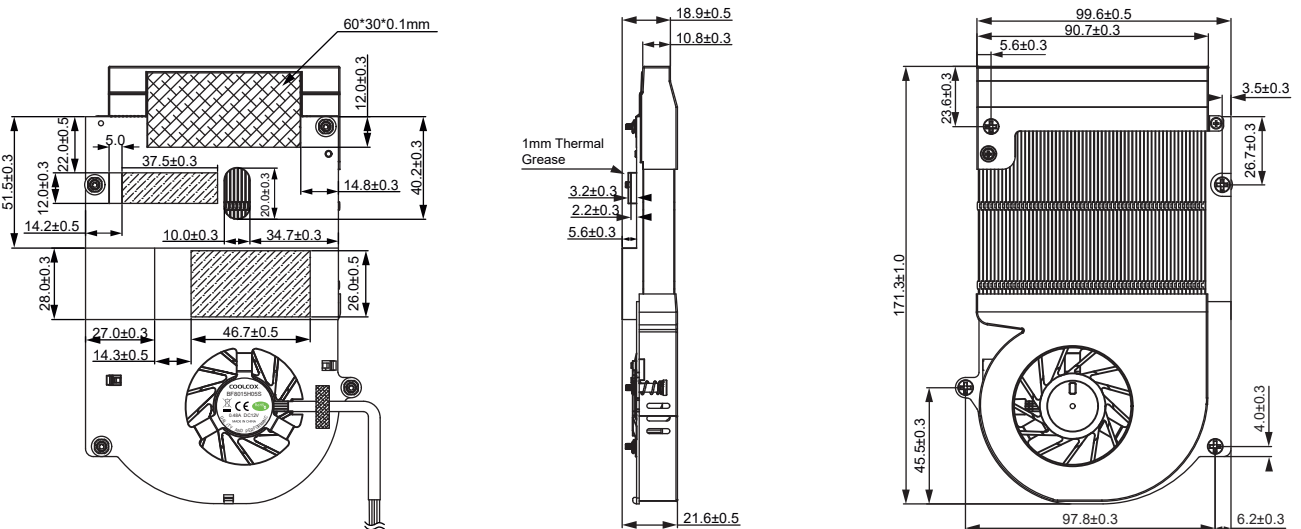

■ 风扇参数 (Fan Parameters)

型号 Model	轴承类型 Bearing Type	电压 Rated Voltage	电压范围 Operation Voltage	电流 Current	功率 Input Power	转速 Speed	风量 Air Flow	风压 Static Pressure	噪音 Noise Level
		VDC	VDC	Amp	Watt	RPM	CFM	MM-H ₂ O	dB-A
CM-FH61A	Hydraulic	5V	4.5~5.5	0.28	1.40	2,500±10%	5.30	6.36	33.5

- * 风扇功能可选择(Function is optional)
- * 噪音值为在无响室测试得到的结果, 测试距离1米(Noise is measured in anechoic chamber, one meter from intake side)
- * 以上为额定电压下的常规参数(All readings are typical values at rated voltage)
- * 规格如有变动不另行通知(Specifications are subjected to change without prior notice)

■ 一般规格 (General Specifications)

- * 风扇轴承类型: 液压轴承
(Fan bearing type: Hydraulic)
- * 风扇材料 (Material):
扇叶 (Impeller): PBT
框 (Housing): PBT & SECC
- * 散热器材质: 铝
(Heatsink: Aluminium)
- * 引线 (Lead wire):
UL1571 AWG #28 or equivalent
红色线正级 Red Wire Positive (+)
黑色线负级 Black Wire Negative (-)
绿色线FG信号 Green Wire Signal (FG)
蓝色线PWM功能 Blue Wire (PWM)
- * 风扇功能 (Fan Functions): FG+PWM
- * 重量 (Weight): 197g



■ 尺寸图 (Dimension Drawing)

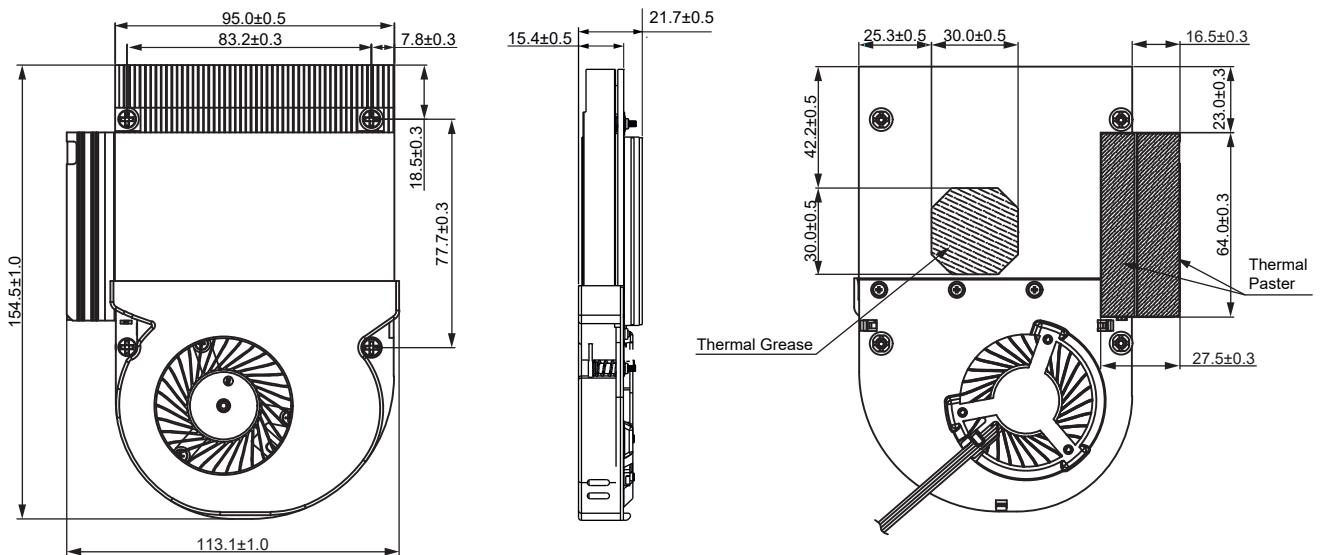

■ 风扇参数 (Fan Parameters)

型号 Model	轴承类型 Bearing Type	电压 Rated Voltage	电压范围 Operation Voltage	电流 Current	功率 Input Power	转速 Speed	风量 Air Flow	风压 Static Pressure	噪音 Noise Level
		VDC	VDC	Amp	Watt	RPM	CFM	MM-H ₂ O	dB-A
CM-FH63	Hydraulic	5V	4.5~5.5	0.50	2.50	3,000±10%	6.94	11.50	35.0

- * 风扇功能可选择 (Function is optional)
- * 噪音值为在无响室测试得到的结果, 测试距离1米 (Noise is measured in anechoic chamber, one meter from intake side)
- * 以上为额定电压下的常规参数 (All readings are typical values at rated voltage)
- * 规格如有变动不另行通知 (Specifications are subjected to change without prior notice)

■ 一般规格 (General Specifications)

- * 风扇轴承类型: 液压轴承
(Fan bearing type: Hydraulic)
- * 风扇材料 (Material):
扇叶 (Impeller): PBT
框 (Housing): PBT & Stainless Steel
- * 散热器材质: 铝
(Heatsink: Aluminium)
- * 引线 (Lead wire):
UL1571 AWG #28 or equivalent
红色线正级 Red Wire Positive (+)
黑色线负级 Black Wire Negative (-)
绿色线FG信号 Green Wire Signal (FG)
蓝色线PWM功能 Blue Wire (PWM)
- * 风扇功能 (Fan Functions): FG+PWM
- * 重量 (Weight): 198g



■ 尺寸图 (Dimension Drawing)

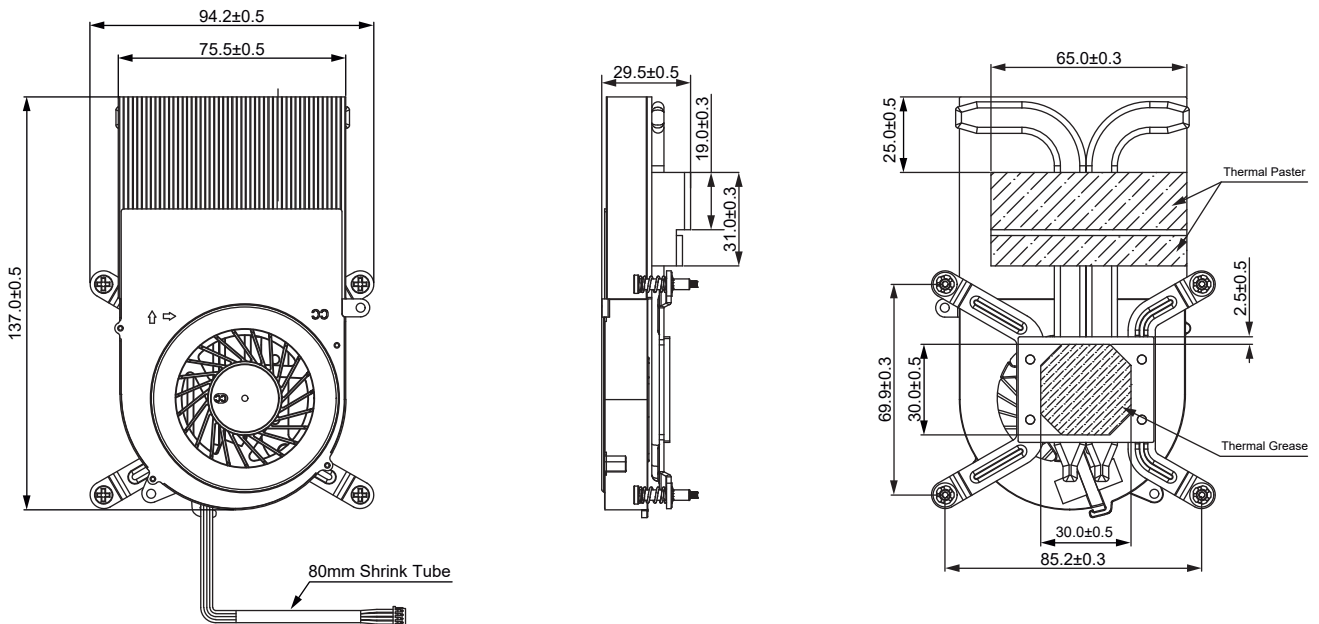

■ 风扇参数 (Fan Parameters)

型号 Model	轴承类型 Bearing Type	电压 Rated Voltage	电压范围 Operation Voltage	电流 Current	功率 Input Power	转速 Speed	风量 Air Flow	风压 Static Pressure	噪音 Noise Level
		VDC	VDC	Amp	Watt	RPM	CFM	MM-H ₂ O	dB-A
CM-FH41H	Hydraulic	5V	3.5~5.5	0.37	1.85	3,700±10%	12.4	21.8	38.6

- * 风扇功能可选择 (Function is optional)
- * 噪音值为在无响室测试得到的结果, 测试距离1米 (Noise is measured in anechoic chamber, one meter from intake side)
- * 以上为额定电压下的常规参数 (All readings are typical values at rated voltage)
- * 规格如有变动不另行通知 (Specifications are subjected to change without prior notice)

■ 一般规格 (General Specifications)

- * 风扇轴承类型: 液压轴承
(Fan bearing type: Hydraulic)
- * 风扇材料 (Material):
扇叶 (Impeller): PBT
支架 (Bracket): PBT
- * 散热器材质: 铝
(Heatsink: Aluminium)
- * 引线 (Lead wire):
UL1571 AWG #28 or equivalent
红色线正级 Red Wire Positive (+)
黑色线负级 Black Wire Negative (-)
绿色线FG信号 Green Wire Signal (FG)
蓝色线PWM功能 Blue Wire (PWM)
- * 风扇功能 (Fan Functions): FG+PWM
- * 重量 (Weight): 117g

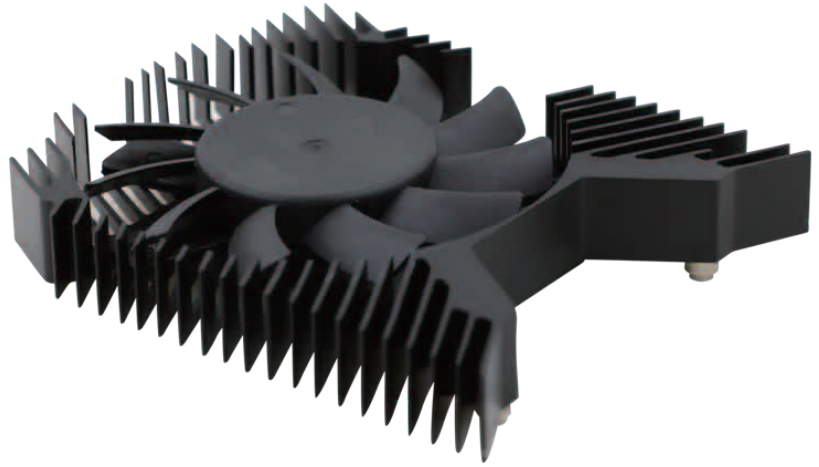

■ 尺寸图 (Dimension Drawing)

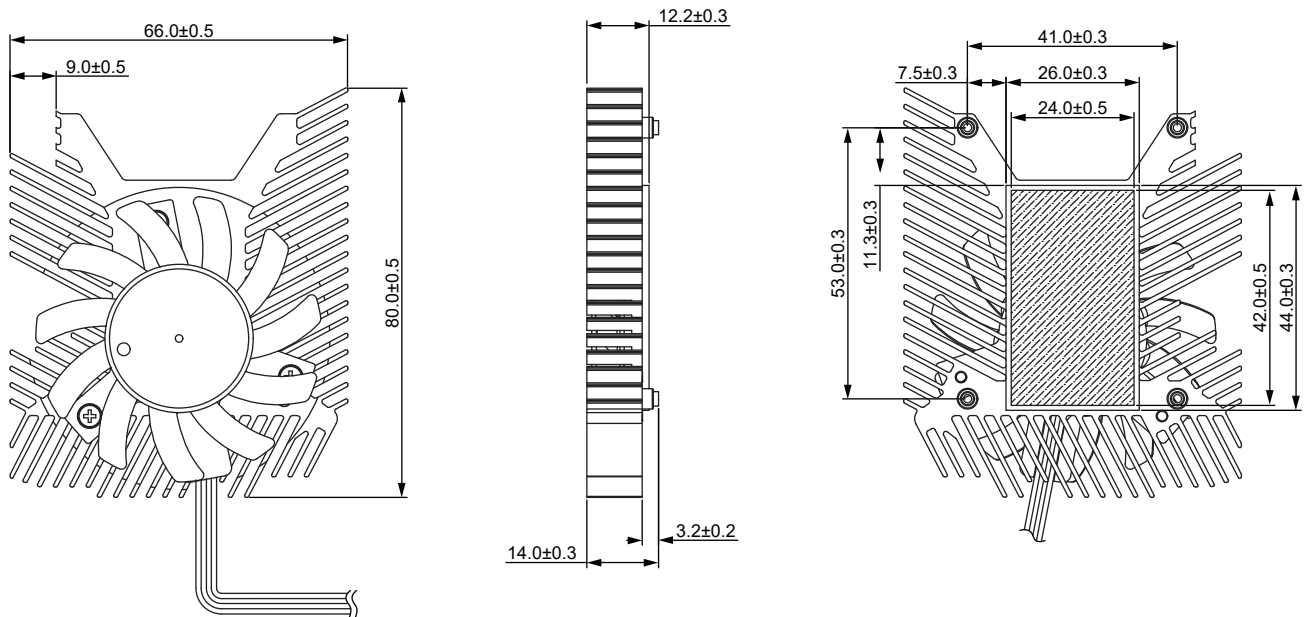

■ 风扇参数 (Fan Parameters)

型号 Model	轴承类型 Bearing Type	电压 Rated Voltage	电压范围 Operation Voltage	电流 Current	功率 Input Power	转速 Speed	风量 Air Flow	风压 Static Pressure	噪音 Noise Level
		VDC	VDC	Amp	Watt	RPM	CFM	MM-H ₂ O	dB-A
CC-IPC191B	Hydraulic	12V	10.8~13.2	0.12	1.44	3,500±10%	7.30	1.75	28.7

- * 风扇功能可选择 (Function is optional)
- * 噪音值为在无响室测试得到的结果, 测试距离1米 (Noise is measured in anechoic chamber, one meter from intake side)
- * 以上为额定电压下的常规参数 (All readings are typical values at rated voltage)
- * 规格如有变动不另行通知 (Specifications are subjected to change without prior notice)

■ 一般规格 (General Specifications)

- * 风扇轴承类型: 液压轴承
(Fan bearing type: Hydraulic)
- * 风扇材料 (Material):
扇叶 (Impeller): PBT
支架 (Bracket): PBT
- * 散热器材质: 铝
(Heatsink: Aluminium)
- * 引线 (Lead wire):
UL1061 AWG #28 or equivalent
红色线正级 Red Wire Positive (+)
黑色线负级 Black Wire Negative (-)
绿色线FG信号 Green Wire Signal (FG)
蓝色线PWM功能 Blue Wire (PWM)
- * 风扇功能 (Fan Functions): FG+PWM
- * 重量 (Weight): 60g



■ 尺寸图 (Dimension Drawing)

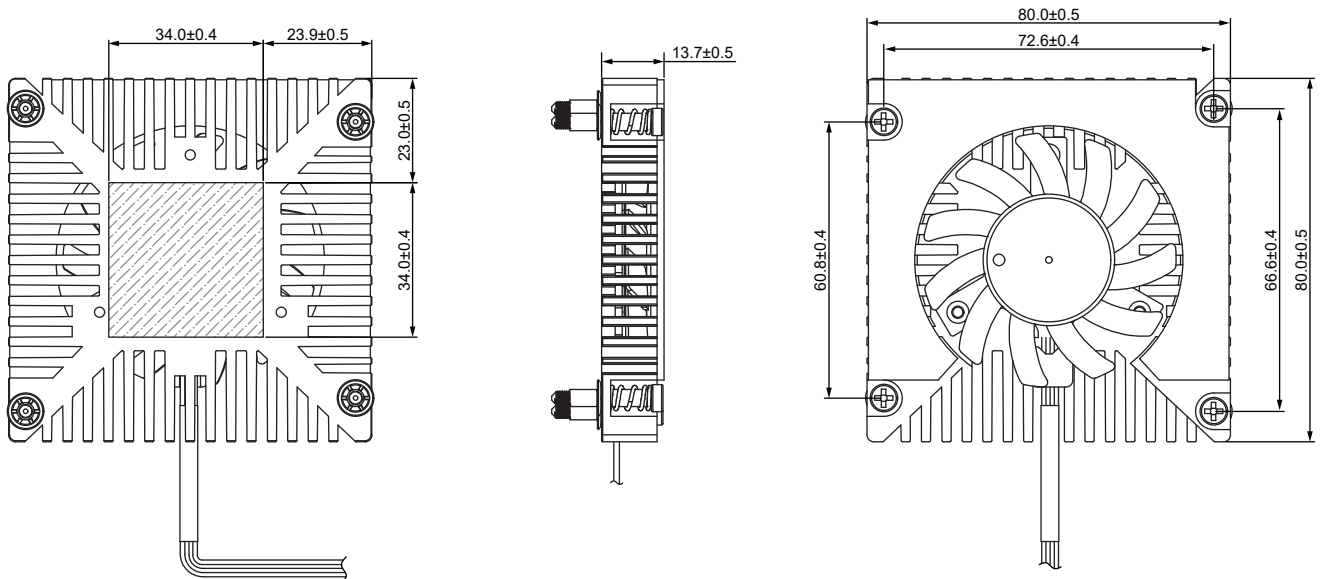

■ 风扇参数 (Fan Parameters)

型号 Model	轴承类型 Bearing Type	电压 Rated Voltage	电压范围 Operation Voltage	电流 Current	功率 Input Power	转速 Speed	风量 Air Flow	风压 Static Pressure	噪音 Noise Level
		VDC	VDC	Amp	Watt	RPM	CFM	MM-H ₂ O	dB-A
CM-EH43	Hydraulic	5V	3.5~5.5	0.22	1.10	3,300±10%	6.41	1.67	31.9

- * 风扇功能可选择 (Function is optional)
- * 噪音值为在无响室测试得到的结果, 测试距离1米 (Noise is measured in anechoic chamber, one meter from intake side)
- * 以上为额定电压下的常规参数 (All readings are typical values at rated voltage)
- * 规格如有变动不另行通知 (Specifications are subjected to change without prior notice)

■ 一般规格 (General Specifications)

- * 风扇轴承类型: 液压轴承
(Fan bearing type: Hydraulic)
- * 风扇材料 (Material):
扇叶 (Impeller): PBT
支架 (Bracket): PBT
- * 散热器材质: 铝
(Heatsink: Aluminium)
- * 引线 (Lead wire):
UL1571 AWG #30 or equivalent
红色线正级 Red Wire Positive (+)
黑色线负级 Black Wire Negative (-)
绿色线FG信号 Green Wire Signal (FG)
蓝色线PWM功能 Blue Wire (PWM)
- * 风扇功能 (Fan Functions): FG+PWM
- * 重量 (Weight): 62.0g



■ 尺寸图 (Dimension Drawing)

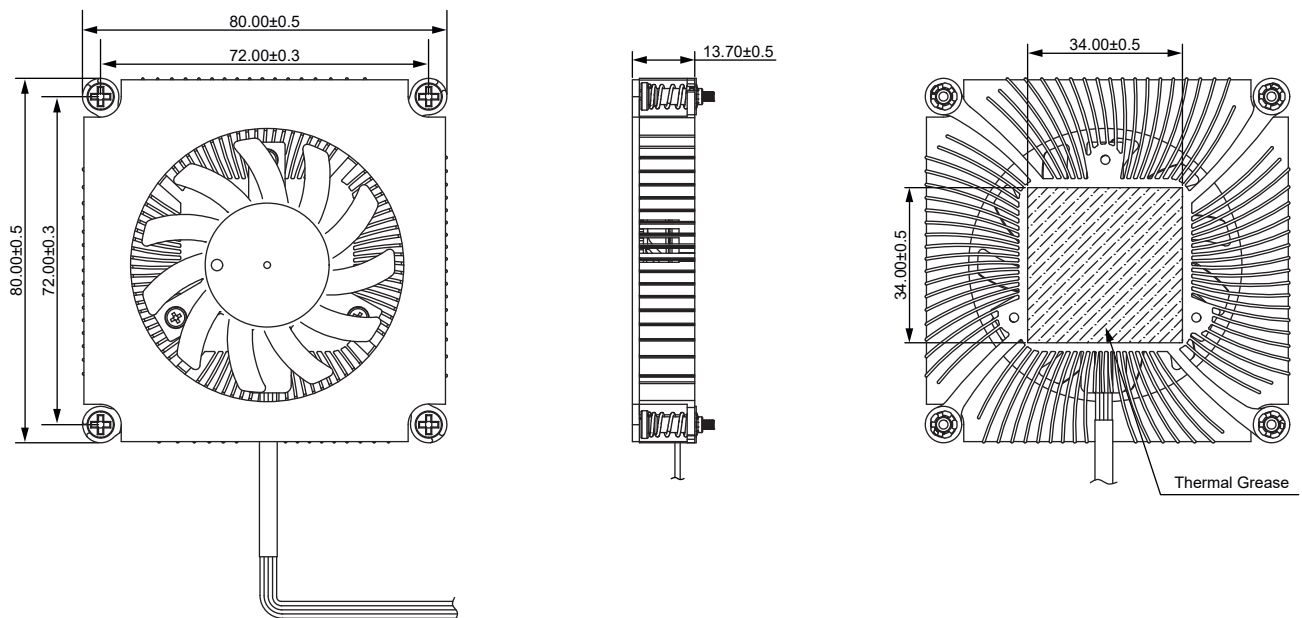

■ 风扇参数 (Fan Parameters)

型号 Model	轴承类型 Bearing Type	电压 Rated Voltage	电压范围 Operation Voltage	电流 Current	功率 Input Power	转速 Speed	风量 Air Flow	风压 Static Pressure	噪音 Noise Level
		VDC	VDC	Amp	Watt	RPM	CFM	MM-H ₂ O	dB-A
CM-EH41C	Hydraulic	5V	3.5~5.5	0.23	1.15	3,500±10%	5.90	1.68	28.6

- * 风扇功能可选择 (Function is optional)
- * 噪音值为在无响室测试得到的结果, 测试距离1米 (Noise is measured in anechoic chamber, one meter from intake side)
- * 以上为额定电压下的常规参数 (All readings are typical values at rated voltage)
- * 规格如有变动不另行通知 (Specifications are subjected to change without prior notice)

■ 一般规格 (General Specifications)

- * 风扇轴承类型: 液压轴承
(Fan bearing type: Hydraulic)
- * 风扇材料 (Material):
扇叶 (Impeller): PBT
框 (Housing): PBT & SECC
- * 散热器材质: 铝
(Heatsink: Aluminium)
- * 引线 (Lead wire):
UL1571 AWG #30 or equivalent
红色线正级 Red Wire Positive (+)
黑色线负级 Black Wire Negative (-)
绿色线FG信号 Green Wire Signal (FG)
蓝色线PWM功能 Blue Wire (PWM)
- * 风扇功能 (Fan Functions): FG+PWM
- * 重量 (Weight): 137g



■ 尺寸图 (Dimension Drawing)

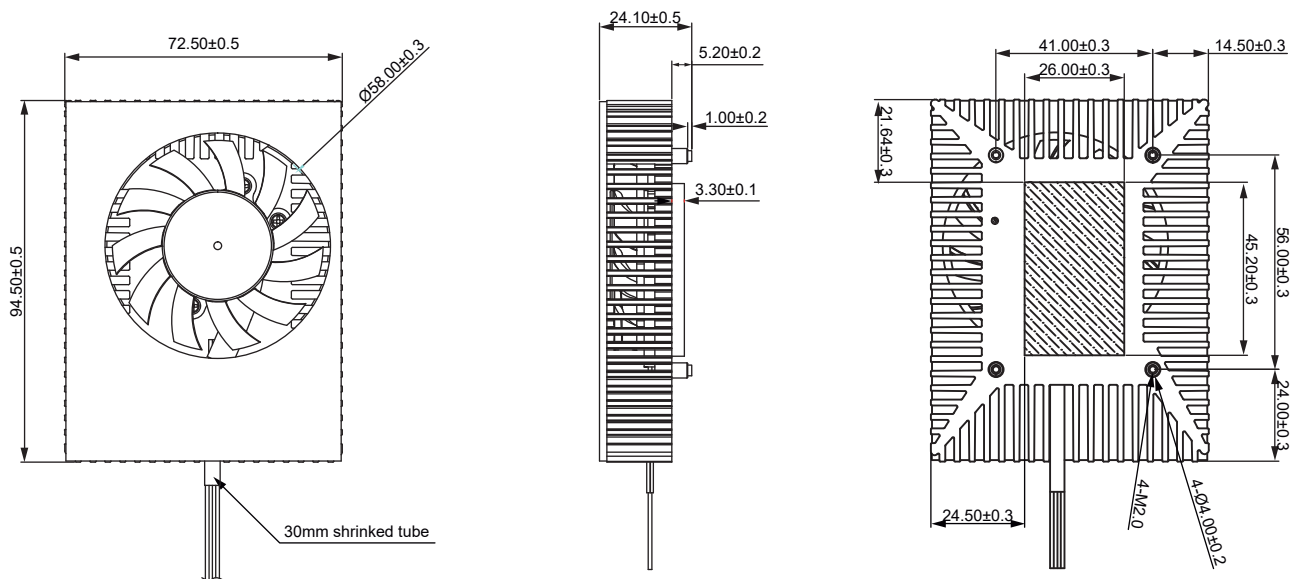

■ 风扇参数 (Fan Parameters)

型号 Model	轴承类型 Bearing Type	电压 Rated Voltage	电压范围 Operation Voltage	电流 Current	功率 Input Power	转速 Speed	风量 Air Flow	风压 Static Pressure	噪音 Noise Level
		VDC	VDC	Amp	Watt	RPM	CFM	MM-H ₂ O	dB-A
CM-EHA3A	Hydraulic	5V	4.5~5.5	0.20	1.00	3,000±10%	5.86	1.44	26.1

- * 风扇功能可选择 (Function is optional)
- * 噪音值为在无响室测试得到的结果, 测试距离1米 (Noise is measured in anechoic chamber, one meter from intake side)
- * 以上为额定电压下的常规参数 (All readings are typical values at rated voltage)
- * 规格如有变动不另行通知 (Specifications are subjected to change without prior notice)

■ 一般规格 (General Specifications)

- * 风扇轴承类型: 液压轴承
(Fan bearing type: Hydraulic)
- * 风扇材料 (Material):
扇叶 (Impeller): PBT
支架 (Bracket): PBT
- * 散热器材质: 铝
(Heatsink: Aluminium)
- * 引线 (Lead wire):
UL1571 AWG #30 or equivalent
红色线正级 Red Wire Positive (+)
黑色线负级 Black Wire Negative (-)
绿色线FG信号 Green Wire Signal (FG)
蓝色线PWM功能 Blue Wire (PWM)
- * 风扇功能 (Fan Functions): FG+PWM
- * 重量 (Weight): 69g

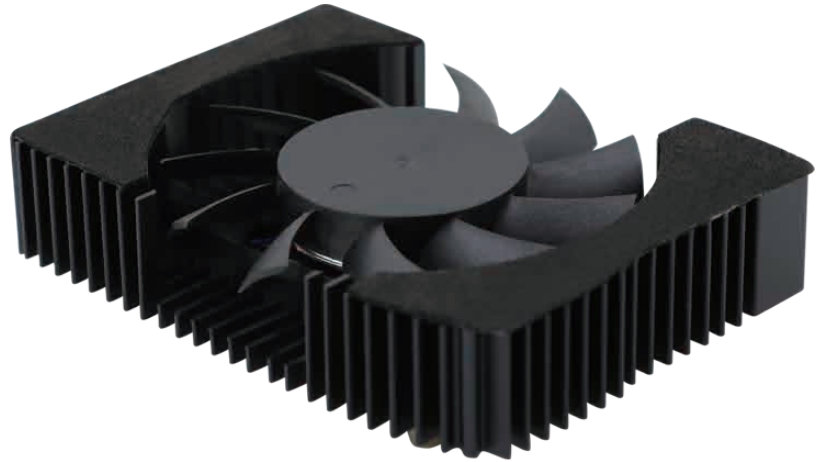

■ 尺寸图 (Dimension Drawing)

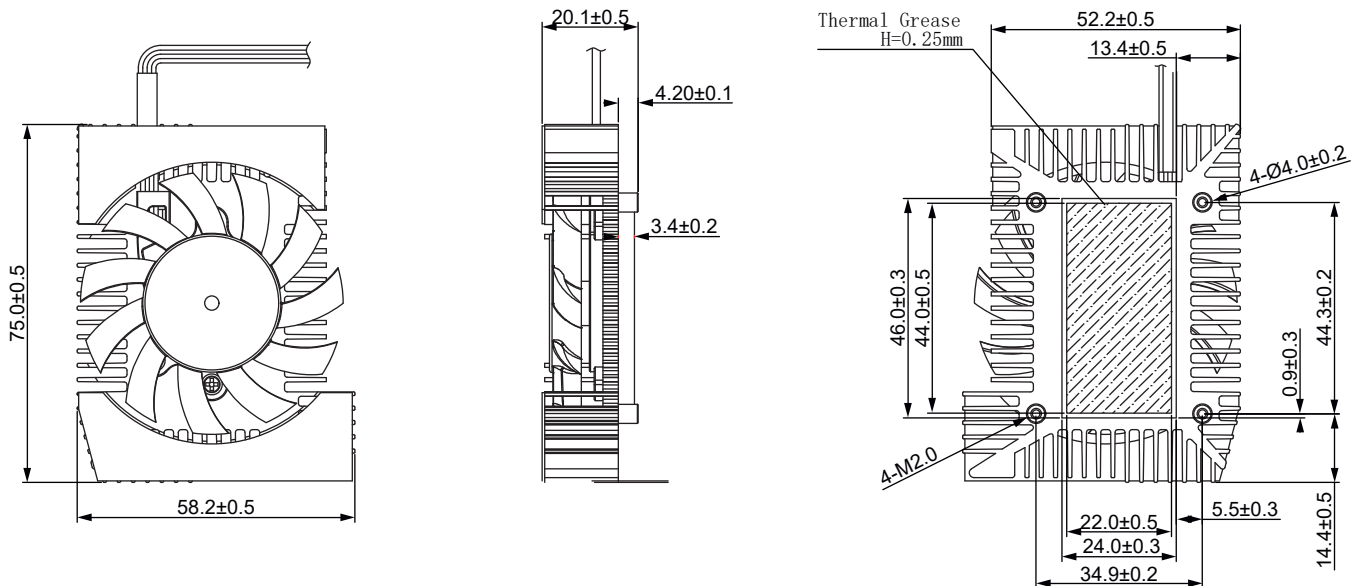

■ 风扇参数 (Fan Parameters)

型号 Model	轴承类型 Bearing Type	电压 Rated Voltage	电压范围 Operation Voltage	电流 Current	功率 Input Power	转速 Speed	风量 Air Flow	风压 Static Pressure	噪音 Noise Level
		VDC	VDC	Amp	Watt	RPM	CFM	MM-H ₂ O	dB-A
CM-EH62	Hydraulic	5V	4.5~5.5	0.20	1.00	3,000±10%	7.46	1.25	26.1

- * 风扇功能可选择 (Function is optional)
- * 噪音值为在无响室测试得到的结果, 测试距离1米 (Noise is measured in anechoic chamber, one meter from intake side)
- * 以上为额定电压下的常规参数 (All readings are typical values at rated voltage)
- * 规格如有变动不另行通知 (Specifications are subjected to change without prior notice)

■ 一般规格 (General Specifications)

- * 风扇轴承类型: 液压轴承
(Fan bearing type: Hydraulic)
- * 风扇材料 (Material):
扇叶 (Impeller): PBT
框 (Housing): PBT & SECC
- * 散热器材质: 铝
(Heatsink: Aluminium)
- * 引线 (Lead wire):
UL1061 AWG #28 or equivalent
红色线正级 Red Wire Positive (+)
黑色线负级 Black Wire Negative (-)
绿色线FG信号 Green Wire Signal (FG)
蓝色线PWM功能 Blue Wire (PWM)
- * 风扇功能 (Fan Functions): FG+PWM
- * 重量 (Weight): 245g



■ 尺寸图 (Dimension Drawing)

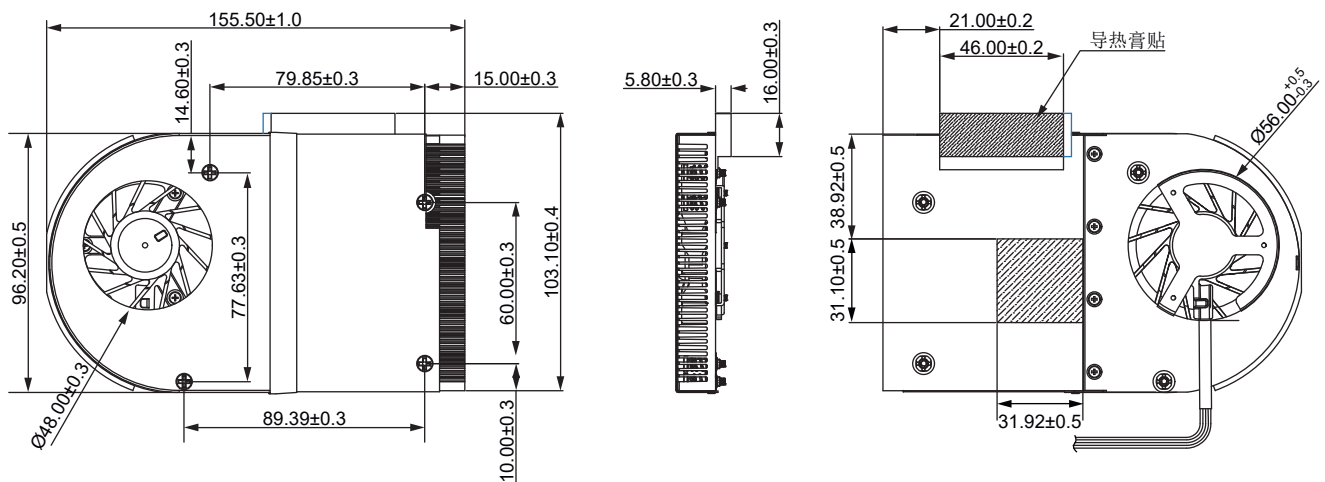

■ 风扇参数 (Fan Parameters)

型号 Model	轴承类型 Bearing Type	电压 Rated Voltage	电压范围 Operation Voltage	电流 Current	功率 Input Power	转速 Speed	风量 Air Flow	风压 Static Pressure	噪音 Noise Level
		VDC	VDC	Amp	Watt	RPM	CFM	MM-H ₂ O	dB-A
CM-EH43B	Hydraulic	5V	4.5~5.5	0.36	2.00	3,500±10%	4.68	5.61	41.0

- * 风扇功能可选择 (Function is optional)
- * 噪音值为在无响室测试得到的结果, 测试距离1米 (Noise is measured in anechoic chamber, one meter from intake side)
- * 以上为额定电压下的常规参数 (All readings are typical values at rated voltage)
- * 规格如有变动不另行通知 (Specifications are subjected to change without prior notice)

■ 一般规格 (General Specifications)

- * 风扇轴承类型: 液压轴承
(Fan bearing type: Hydraulic)
- * 风扇材料 (Material):
扇叶 (Impeller): PBT
框 (Housing): PBT & SECC
- * 散热器材质: 铝
(Heatsink: Aluminium)
- * 引线 (Lead wire):
UL1061 AWG #28 or equivalent
红色线正级 Red Wire Positive (+)
黑色线负级 Black Wire Negative (-)
绿色线FG信号 Green Wire Signal (FG)
蓝色线PWM功能 Blue Wire (PWM)
- * 风扇功能 (Fan Functions): FG+PWM
- * 重量 (Weight): 245g



■ 尺寸图 (Dimension Drawing)

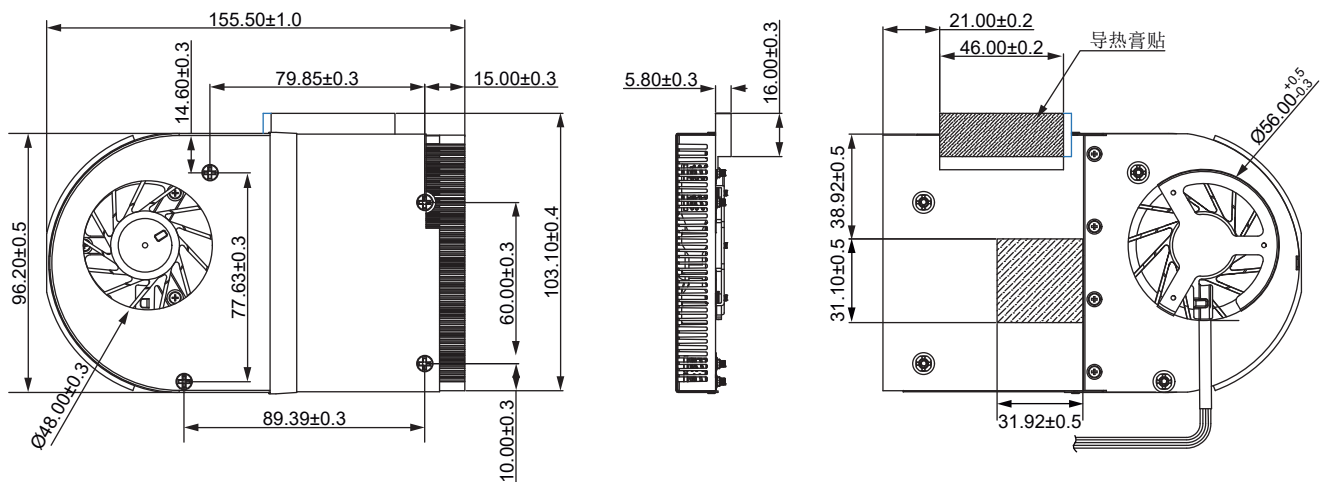

■ 风扇参数 (Fan Parameters)

型号 Model	轴承类型 Bearing Type	电压 Rated Voltage	电压范围 Operation Voltage	电流 Current	功率 Input Power	转速 Speed	风量 Air Flow	风压 Static Pressure	噪音 Noise Level
		VDC	VDC	Amp	Watt	RPM	CFM	MM-H ₂ O	dB-A
CM-EH43B	Hydraulic	5V	4.5~5.5	0.36	2.00	3,500±10%	4.68	5.61	41.0

- * 风扇功能可选择 (Function is optional)
- * 噪音值为在无响室测试得到的结果, 测试距离1米 (Noise is measured in anechoic chamber, one meter from intake side)
- * 以上为额定电压下的常规参数 (All readings are typical values at rated voltage)
- * 规格如有变动不另行通知 (Specifications are subjected to change without prior notice)

■ 一般规格 (General Specifications)

- * 风扇轴承类型: 液压轴承
(Fan bearing type: Hydraulic)
- * 风扇材料 (Material):
扇叶 (Impeller): PBT
框 (Housing): PBT
- * 散热器材质: 铝
(Heatsink: Aluminium)
- * 引线 (Lead wire):
UL1061 AWG #28 or equivalent
红色线正级 Red Wire Positive (+)
黑色线负级 Black Wire Negative (-)
绿色线FG信号 Green Wire Signal (FG)
蓝色线PWM功能 Blue Wire (PWM)
- * 风扇功能 (Fan Functions): FG+PWM
- * 重量 (Weight): 89g



■ 尺寸图 (Dimension Drawing)

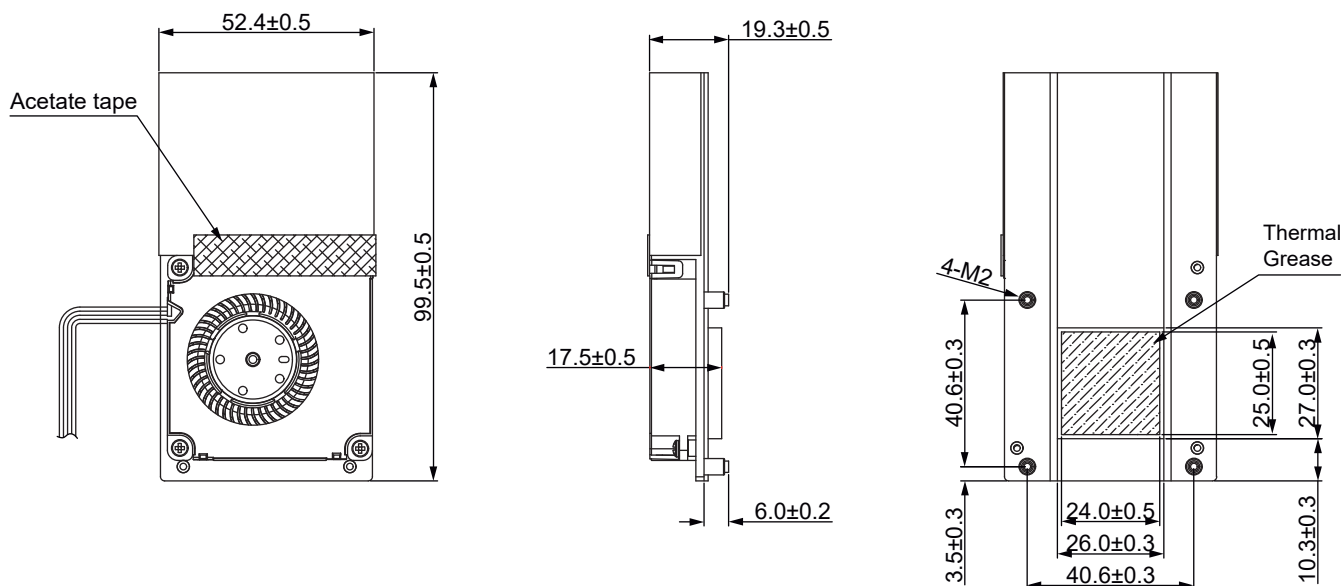

■ 风扇参数 (Fan Parameters)

型号 Model	轴承类型 Bearing Type	电压 Rated Voltage	电压范围 Operation Voltage	电流 Current	功率 Input Power	转速 Speed	风量 Air Flow	风压 Static Pressure	噪音 Noise Level
		VDC	VDC	Amp	Watt	RPM	CFM	MM-H ₂ O	dB-A
CM-EHA3B	Hydraulic	5V	3.0~5.5	0.18	0.90	5,000±10%	2.58	7.47	34.8

- * 风扇功能可选择 (Function is optional)
- * 噪音值为在无响室测试得到的结果, 测试距离1米 (Noise is measured in anechoic chamber, one meter from intake side)
- * 以上为额定电压下的常规参数 (All readings are typical values at rated voltage)
- * 规格如有变动不另行通知 (Specifications are subjected to change without prior notice)

■ 一般规格 (General Specifications)

- * 风扇轴承类型: 液压轴承
(Fan bearing type: Hydraulic)
- * 风扇材料 (Material):
扇叶 (Impeller): PBT
框 (Housing): PBT
- * 散热器材质: 铝
(Heatsink: Aluminium)
- * 引线 (Lead wire):
UL1061 AWG #28 or equivalent
红色线正级 Red Wire Positive (+)
黑色线负级 Black Wire Negative (-)
绿色线FG信号 Green Wire Signal (FG)
蓝色线PWM功能 Blue Wire (PWM)
- * 风扇功能 (Fan Functions): FG+PWM
- * 重量 (Weight): 236g



■ 尺寸图 (Dimension Drawing)

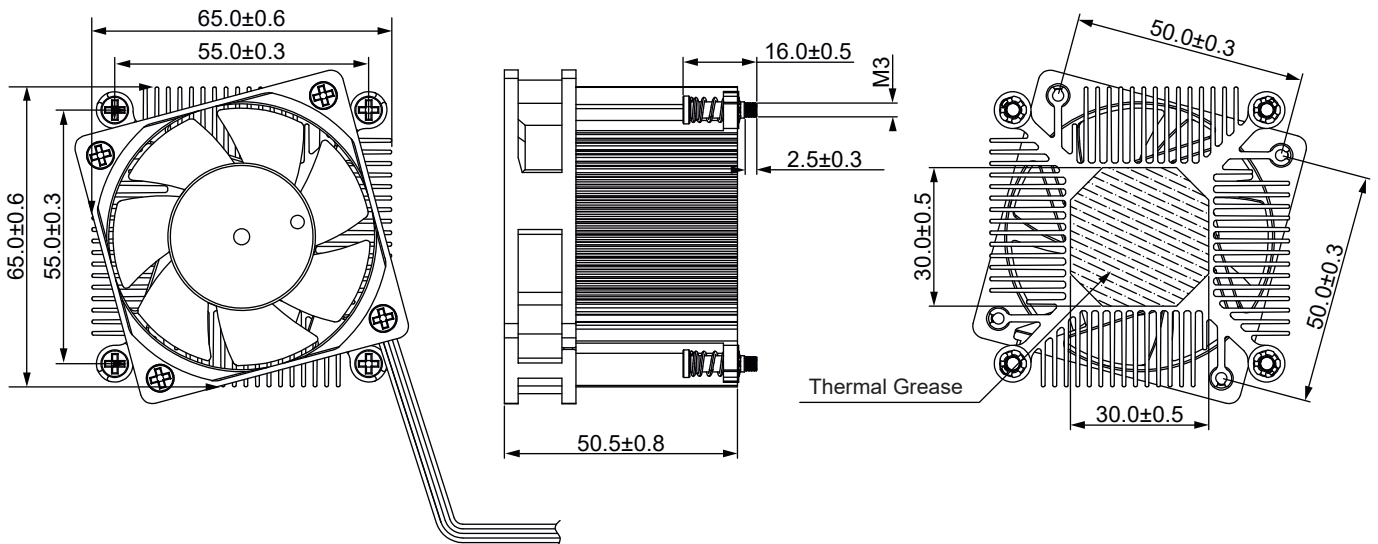

■ 风扇参数 (Fan Parameters)

型号 Model	轴承类型 Bearing Type	电压 Rated Voltage	电压范围 Operation Voltage	电流 Current	功率 Input Power	转速 Speed	风量 Air Flow	风压 Static Pressure	噪音 Noise Level
		VDC	VDC	Amp	Watt	RPM	CFM	MM-H ₂ O	dB-A
CM-EH20CD	Hydraulic	12V	6.0~13.5	0.07	0.84	4,000±10%	8.10	4.14	30.6

- * 风扇功能可选择 (Function is optional)
- * 噪音值为在无响室测试得到的结果, 测试距离1米 (Noise is measured in anechoic chamber, one meter from intake side)
- * 以上为额定电压下的常规参数 (All readings are typical values at rated voltage)
- * 规格如有变动不另行通知 (Specifications are subjected to change without prior notice)