

COOLCOX®

东莞市奇凌电子科技有限公司
COOLCOX LIMITED

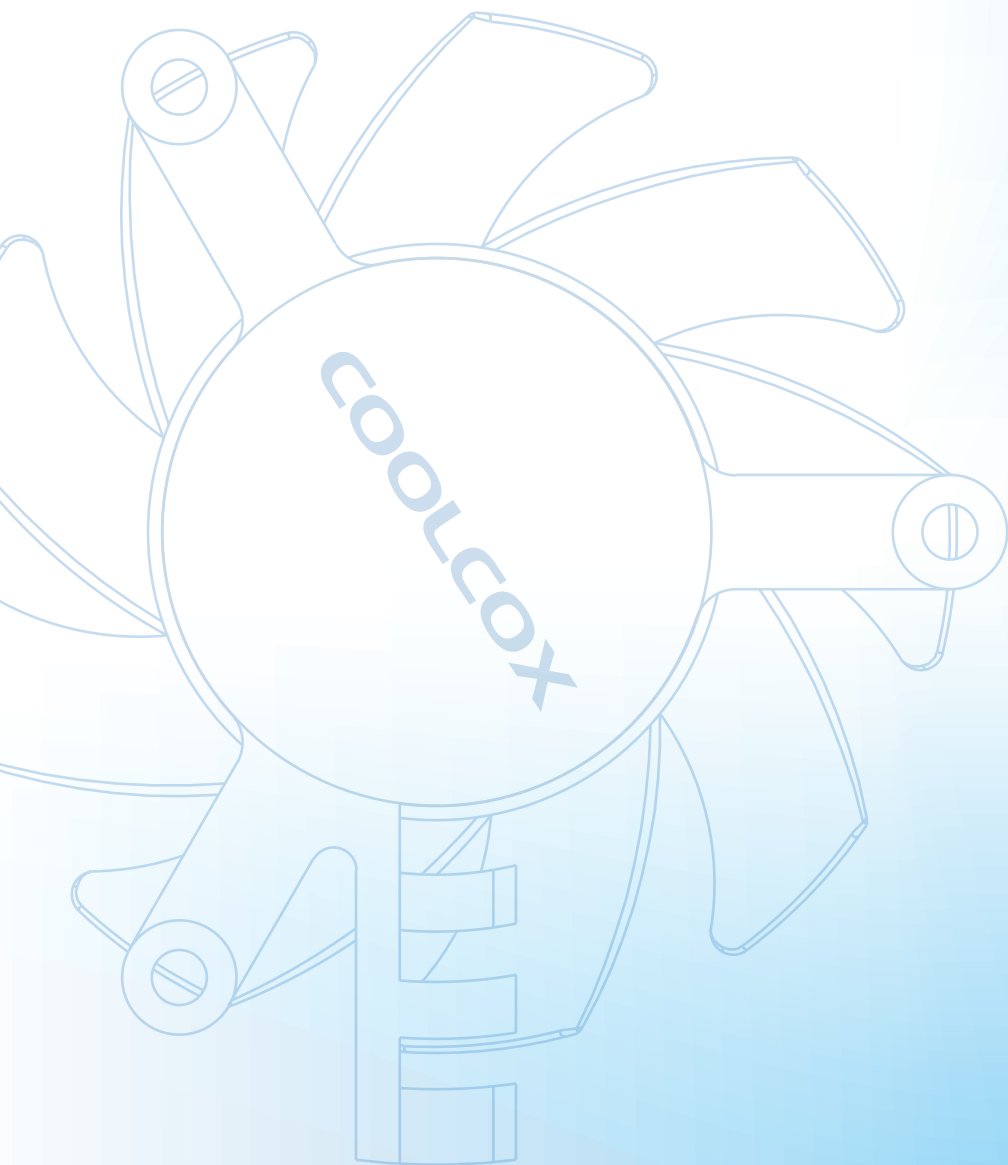

COMPANY PROFILE

CoolCox was founded in 2008 and dedicated to the research and production of cooling products. It is a high-tech enterprise with own brand and intellectual property rights.

The manufacturing factory was located in Dongguan city, with manufacturing area of 18,000 square meters and more than 700 employees. The company fully implements ISO9001, ISO14001, IATF16949, QC080000 management systems; and the products comply with safety regulations such as UL, TUV, CE, and CQC.

Our company has advanced automation equipment and first-class manufacturing capabilities, as well as a strict quality management system, continuously providing high-performance axial fans, blowers, coolers, motors and more to global customers, widely used in fields such as computers, network equipment, household appliances, medical equipment, security products, automation & control systems, 3D printers, projectors, new energy, etc.

We insist on technology & innovation and quality assurance, to achieve value growth for customers with comprehensive and efficient cooling products and solutions.



II Introductions (风扇介绍)

- All parts are in conformity with RoHS2.0 standard
风扇所有部件符合RoHS2.0标准
- Various bearings for option:Sleeve,Hydraulic,1-Ball & 1 Sleeve,2-Ball
含油，液压，单滚珠，双滚珠多种轴承可供选择
- Locked rotor protection and polarity protection is optional
可选择增加锁机保护和极性保护功能
- Frequency generator and rotation detector function are optional
可选择增加FG信号或RD信号功能 (FG信号输出风扇转速;RD信号可以监测风扇是否正常运转)

II Part Number Definition (产品型号命名规则)

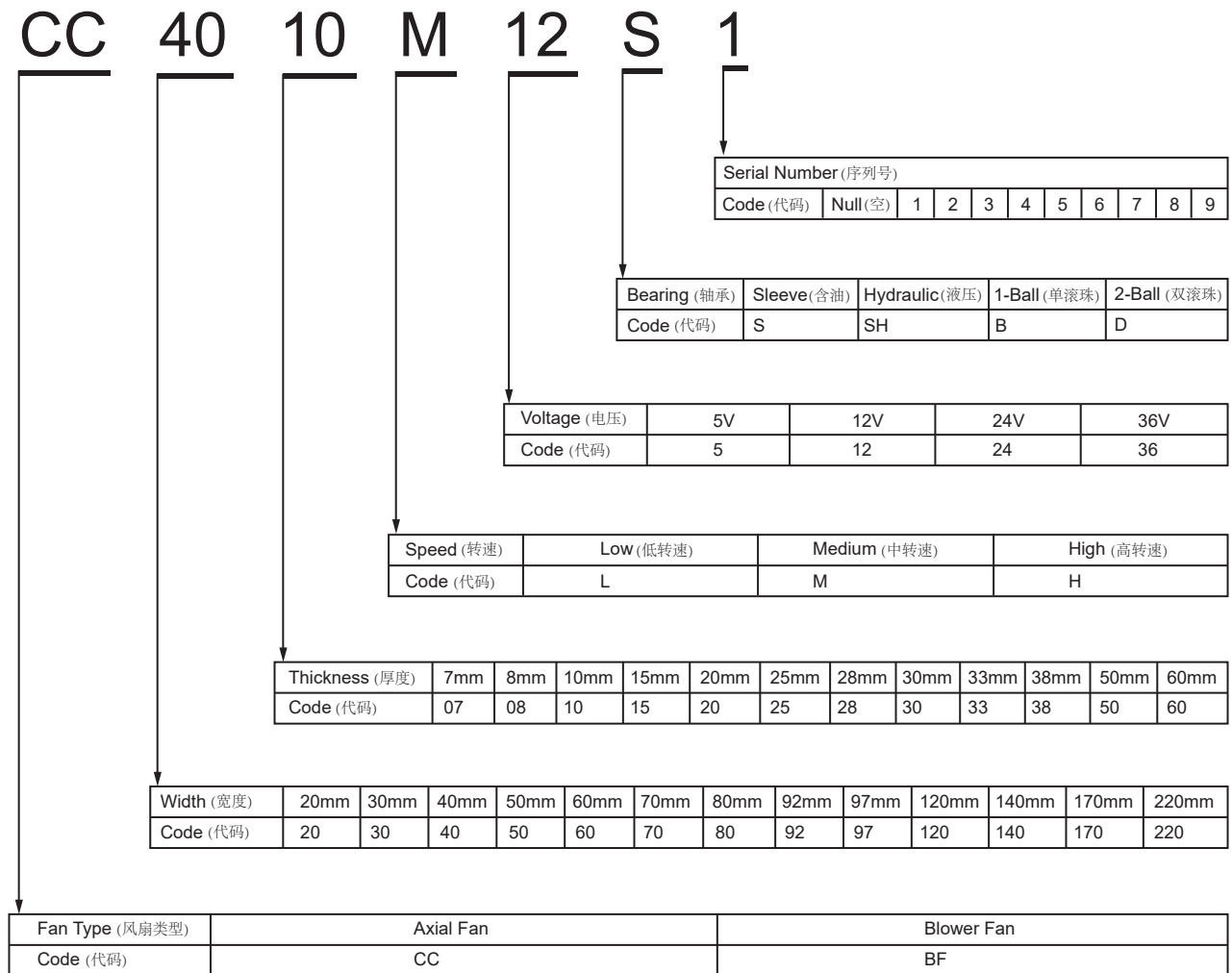

Frameless Fan $\Phi 28 \times 10 \text{mm}$

■ 尺寸图 (DIMENSION DRAWING)

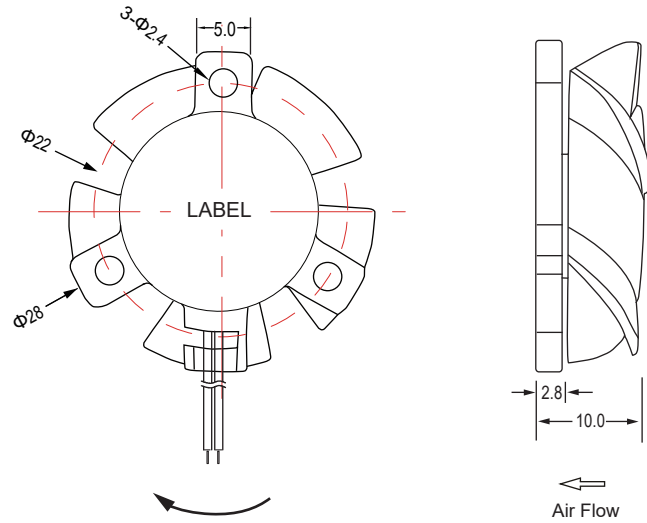

- * 轴承类型: 含油轴承, 双滚珠轴承, 液压轴承
(Bearing type: Sleeve, 2-Ball, Hydraulic)
- * 材料(Material):
支架(Bracket): PBT 叶(Blade): PBT
- * 引线(Lead wire):
UL1571 AWG #28 or equivalent
红色线正级 Red Wire Positive (+)
黑色线负级 Black Wire Negative (-)
- * 可选择增加风扇功能(Functions are optional)
- * 重量(Weight): 6g

■ 风压&风量曲线图 P and Q CURVE

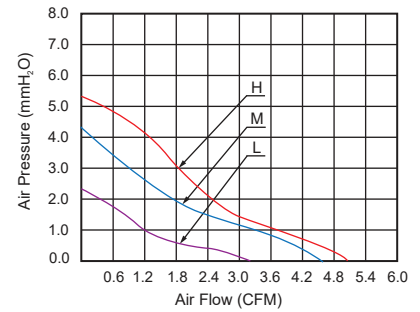

型号 Model	轴承类型 Bearing Type	风扇类型 Fan Type	电压 Rated Voltage	电流 Current	功率 Input Power	转速 Speed	风量 Air Flow	风压 Static Pressure	噪音 Noise Level
			VDC	Amp	Watt	RPM	CFM	MM-H ₂ O	dBA
CC3010L05S	Sleeve	Frameless	5V	0.08	0.40	7,000±10%	3.10	2.20	22.0
CC3010L05D	2-Ball								
CC3010L05SH	Hydraulic								
CC3010M05S	Sleeve	Frameless	5V	0.10	0.50	9,000±10%	4.50	4.20	24.0
CC3010M05D	2-Ball								
CC3010M05SH	Hydraulic								
CC3010H05S	Sleeve	Frameless	5V	0.16	0.80	11,000±10%	4.90	5.10	30.0
CC3010H05D	2-Ball								
CC3010H05SH	Hydraulic								
CC3010L12S	Sleeve	Frameless	12V	0.02	0.24	7,000±10%	3.10	2.20	22.0
CC3010L12D	2-Ball								
CC3010L12SH	Hydraulic								
CC3010M12S	Sleeve	Frameless	12V	0.04	0.48	9,000±10%	4.50	4.20	24.0
CC3010M12D	2-Ball								
CC3010M12SH	Hydraulic								
CC3010H12S	Sleeve	Frameless	12V	0.05	0.60	11,000±10%	4.90	5.10	30.0
CC3010H12D	2-Ball								
CC3010H12SH	Hydraulic								

- * 以上为额定电压下的常规参数(All readings are typical values at rated voltage)
- * 规格如有变动不另行通知(Specifications are subjected to change without prior notice)

Frameless Fan Φ32x10mm

■ 尺寸图 (DIMENSION DRAWING)

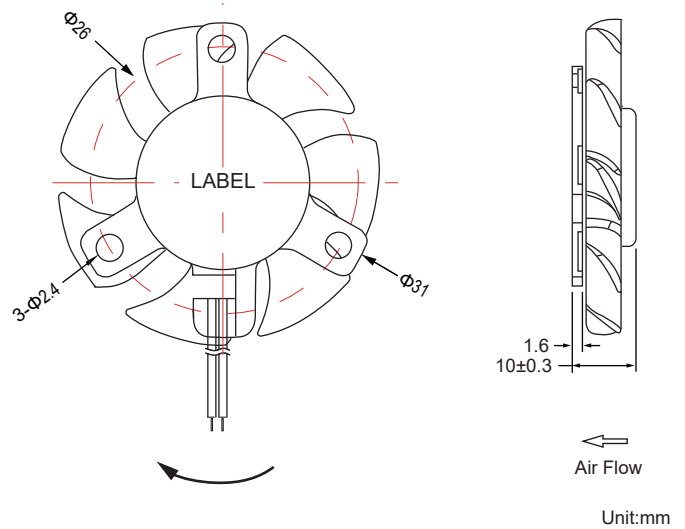

Unit:mm

- * 轴承类型: 含油轴承, 双滚珠轴承, 液压轴承
(Bearing type:Sleeve,2-Ball,Hydraulic)
- * 材料(Material):
支架(Bracket):PBT 叶(Blade):PBT
- * 引线(Lead wire):
UL1571 AWG #28 or equivalent
红色线正级 Red Wire Positive (+)
黑色线负级 Black Wire Negative (-)
- * 可选择增加风扇功能(Functions are optional)
- * 重量(Weight):6.0g

■ 风压&风量曲线图 P and Q CURVE

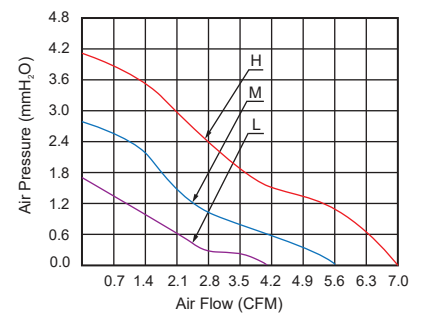

型号 Model	轴承类型 Bearing Type	风扇类型 Fan Type	电压 Rated Voltage	电流 Current	功率 Input Power	转速 Speed	风量 Air Flow	风压 Static Pressure	噪音 Noise Level
			VDC	Amp	Watt	RPM	CFM	MM-H ₂ O	dBA
CC3510L05S	Sleeve	Frameless	5V	0.05	0.25	5,000±10%	4.00	1.70	21.0
CC3510L05D	2-Ball								
CC3510L05SH	Hydraulic								
CC3510M05S	Sleeve	Frameless	5V	0.09	0.45	7,000±10%	5.60	2.80	26.0
CC3510M05D	2-Ball								
CC3510M05SH	Hydraulic								
CC3510H05S	Sleeve	Frameless	5V	0.26	1.30	9,000±10%	7.00	4.10	33.0
CC3510H05D	2-Ball								
CC3510H05SH	Hydraulic								
CC3510L12S	Sleeve	Frameless	12V	0.02	0.24	5,000±10%	4.00	1.70	21.0
CC3510L12D	2-Ball								
CC3510L12SH	Hydraulic								
CC3510M12S	Sleeve	Frameless	12V	0.10	1.20	7,000±10%	5.60	2.80	26.0
CC3510M12D	2-Ball								
CC3510M12SH	Hydraulic								
CC3510H12S	Sleeve	Frameless	12V	0.12	1.44	9,000±10%	7.00	4.10	33.0
CC3510H12D	2-Ball								
CC3510H12SH	Hydraulic								

- * 以上为额定电压下的常规参数(All readings are typical values at rated voltage)
- * 规格如有变动不另行通知(Specifications are subjected to change without prior notice)

Frameless Fan $\Phi 37.5 \times 10 \text{mm}$

■ 尺寸图 (DIMENSION DRAWING)

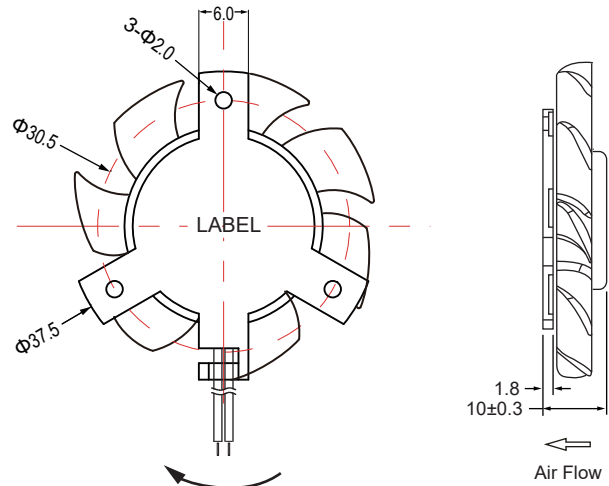

Unit:mm

- * 轴承类型: 含油轴承, 双滚珠轴承, 液压轴承 (Bearing type: Sleeve, 2-Ball, Hydraulic)
- * 材料(Material):
支架(Bracket): PBT 叶(Blade): PBT
- * 引线(Lead wire):
UL2468 AWG #26 or equivalent
红色线正级 Red Wire Positive (+)
黑色线负级 Black Wire Negative (-)
- * 可选择增加风扇功能(Functions are optional)
- * 重量(Weight): 9.0g

■ 风压&风量曲线图 P and Q CURVE

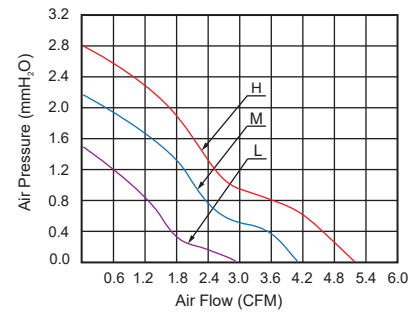

型号 Model	轴承类型 Bearing Type	风扇类型 Fan Type	版本 Version	电压 Rated Voltage	电流 Current	转速 Speed	风量 Air Flow	风压 Static Pressure	噪音 Noise Level
				VDC	Amp	RPM	CFM	MM-H ₂ O	dBA
CC4010L05S	Sleeve	Frameless	-A	5V	0.08	4,000±10%	2.90	1.50	21.0
CC4010L05D	2-Ball								
CC4010L05SH	Hydraulic								
CC4010M05S	Sleeve	Frameless	-A	5V	0.12	5,000±10%	3.90	2.20	25.0
CC4010M05D	2-Ball								
CC4010M05SH	Hydraulic								
CC4010H05S	Sleeve	Frameless	-A	5V	0.22	6,000±10%	5.10	2.80	28.5
CC4010H05D	2-Ball								
CC4010H05SH	Hydraulic								
CC4010L12S	Sleeve	Frameless	-A	12V	0.03	4,000±10%	2.90	1.50	21.0
CC4010L12D	2-Ball								
CC4010L12SH	Hydraulic								
CC4010M12S	Sleeve	Frameless	-A	12V	0.05	5,000±10%	3.90	2.20	25.0
CC4010M12D	2-Ball								
CC4010M12SH	Hydraulic								
CC4010H12S	Sleeve	Frameless	-A	12V	0.08	6,000±10%	5.10	2.80	28.5
CC4010H12D	2-Ball								
CC4010H12SH	Hydraulic								

- * 以上为额定电压下的常规参数(All readings are typical values at rated voltage)
- * 规格如有变动不另行通知(Specifications are subjected to change without prior notice)

Frameless Fan Φ36x10mm

■ 尺寸图 (DIMENSION DRAWING)

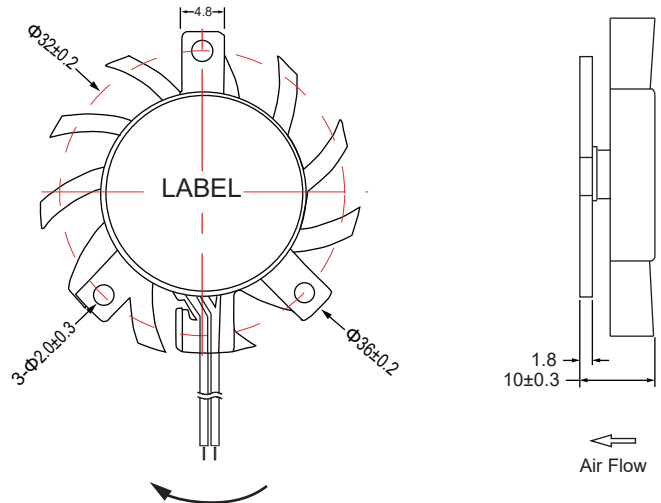

Unit:mm

■ 风压&风量曲线图 P and Q CURVE

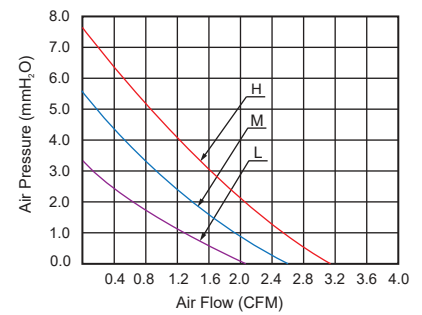

- * 轴承类型: 含油轴承, 双滚珠轴承 (Bearing type:Sleeve,2-Ball)
- * 材料(Material):
支架(Bracket):PBT 叶(Blade):PBT
- * 引线(Lead wire):
UL1061 AWG #26 or equivalent
红色线正级 Red Wire Positive (+)
黑色线负级 Black Wire Negative (-)
- * 可选择增加风扇功能(Functions are optional)
- * 重量(Weight):8.0g

型号 Model	轴承类型 Bearing Type	风扇类型 Fan Type	版本 Version	电压 Rated Voltage	电流 Current	转速 Speed	风量 Air Flow	风压 Static Pressure	噪音 Noise Level
				VDC	Amp	RPM	CFM	MM-H ₂ O	dBA
CC4010L05S	Sleeve	Frameless	-C	5V	0.10	4,000±10%	2.00	3.20	22.0
CC4010L05D	2-Ball								
CC4010M05S	Sleeve	Frameless	-C	5V	0.15	5,000±10%	2.50	5.50	26.0
CC4010M05D	2-Ball								
CC4010H05S	Sleeve	Frameless	-C	5V	0.28	6,000±10%	3.00	7.50	31.0
CC4010H05D	2-Ball								
CC4010L12S	Sleeve	Frameless	-C	12V	0.05	4,000±10%	2.00	3.20	22.0
CC4010L12D	2-Ball								
CC4010M12S	Sleeve	Frameless	-C	12V	0.10	5,000±10%	2.50	5.50	26.0
CC4010M12D	2-Ball								
CC4010H12S	Sleeve	Frameless	-C	12V	0.20	6,000±10%	3.00	7.50	31.0
CC4010H12D	2-Ball								

- * 以上为额定电压下的常规参数(All readings are typical values at rated voltage)
- * 规格如有变动不另行通知(Specifications are subjected to change without prior notice)

Frameless Fan $\Phi 37.5 \times 10 \text{mm}$

■ 尺寸图 (DIMENSION DRAWING)

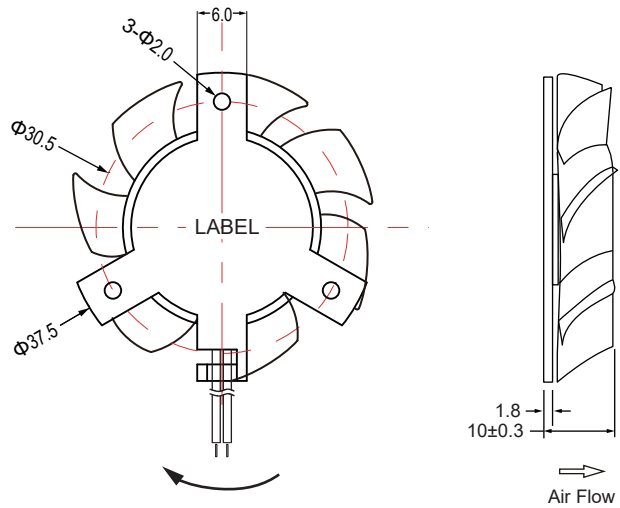

Unit:mm

■ 风压&风量曲线图 P and Q CURVE

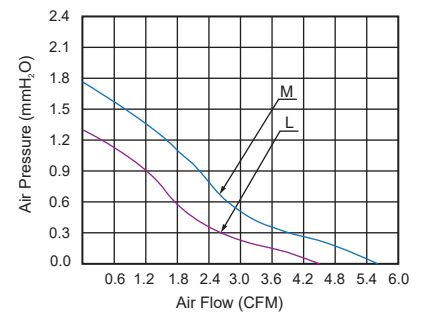

- * 轴承类型: 双滚珠轴承, 液压轴承
(Bearing type: 2-Ball, Hydraulic)
- * 材料(Material):
支架(Bracket): PBT 叶(Blade): PBT
- * 引线(Lead wire):
UL2468 AWG #26 or equivalent
红色线正级 Red Wire Positive (+)
黑色线负级 Black Wire Negative (-)
- * 可选择增加风扇功能(Functions are optional)
- * 重量(Weight): 9.0g

型号 Model	轴承类型 Bearing Type	风扇类型 Fan Type	版本 Version	电压 Rated Voltage	电流 Current	转速 Speed	风量 Air Flow	风压 Static Pressure	噪音 Noise Level
				VDC	Amp	RPM	CFM	MM-H ₂ O	dBA
CC4010L05D	2-Ball	Frameless	-D	5V	0.12	4,000±10%	4.40	1.30	28.0
CC4010L05SH	Hydraulic								
CC4010M05D	2-Ball	Frameless	-D	5V	0.15	5,000±10%	5.60	1.70	33.0
CC4010M05SH	Hydraulic								

- * 以上为额定电压下的常规参数(All readings are typical values at rated voltage)
- * 规格如有变动不另行通知(Specifications are subjected to change without prior notice)

Frameless Fan $\Phi 46 \times 10 \text{mm}$

■ 尺寸图 (DIMENSION DRAWING)

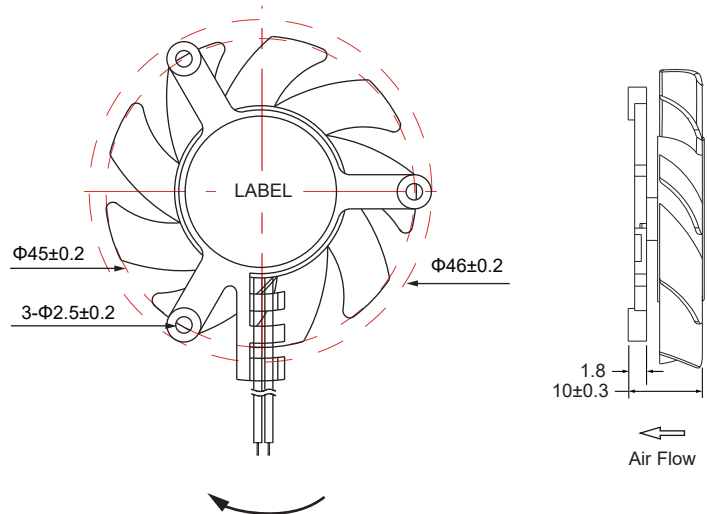

Unit:mm

■ 风压&风量曲线图 P and Q CURVE

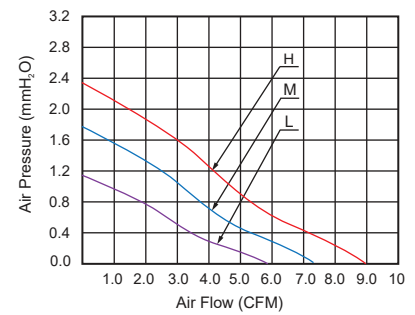

- * 轴承类型: 含油轴承, 双滚珠轴承 (Bearing type:Sleeve,2-Ball)
- * 材料(Material):
支架(Bracket):PBT 叶(Blade):PBT
- * 引线(Lead wire):
UL1061 AWG #26 or equivalent
红色线正级 Red Wire Positive (+)
黑色线负级 Black Wire Negative (-)
- * 可选择增加风扇功能(Functions are optional)
- * 重量(Weight):11.0g

型号 Model	轴承类型 Bearing Type	风扇类型 Fan Type	版本 Version	电压 Rated Voltage	电流 Current	转速 Speed	风量 Air Flow	风压 Static Pressure	噪音 Noise Level
				VDC	Amp	RPM	CFM	MM-H ₂ O	dBA
CC5010L12S	Sleeve	Frameless	-A	12V	0.05	3,500±10%	5.90	1.10	20.0
CC5010L12D	2-Ball								
CC5010M12S	Sleeve	Frameless	-A	12V	0.09	4,500±10%	7.30	1.80	28.0
CC5010M12D	2-Ball								
CC5010H12S	Sleeve	Frameless	-A	12V	0.17	5,500±10%	9.00	2.30	32.0
CC5010H12D	2-Ball								

- * 以上为额定电压下的常规参数(All readings are typical values at rated voltage)
- * 规格如有变动不另行通知(Specifications are subjected to change without prior notice)

Frameless Fan $\Phi 56 \times 8 \text{mm}$

■ 尺寸图 (DIMENSION DRAWING)

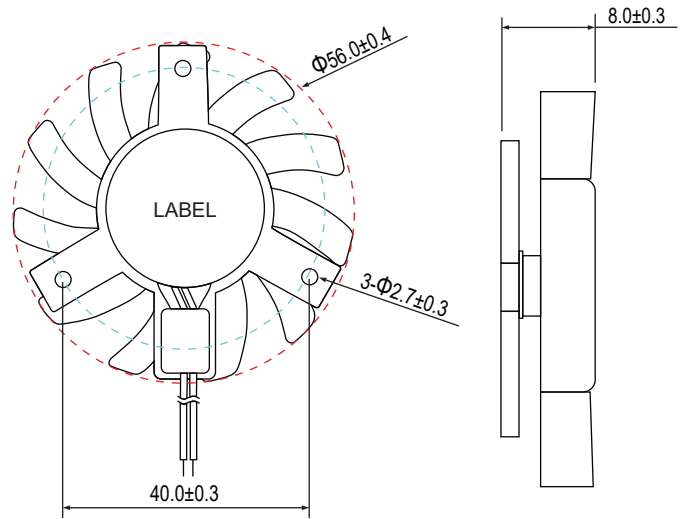

Unit:mm

- * 轴承类型: 液压轴承 (Bearing type: Hydraulic)
- * 材料 (Material): 框叶 (Frame & Impeller): PBT
- * 引线 (Lead wire): UL2468 AWG #28 or equivalent
红色线正级 Red Wire Positive (+)
黑色线负级 Black Wire Negative (-)
- * 可选择增加风扇功能 (Functions are optional)
- * 重量 (Weight): 13g

■ 风压 & 风量曲线图 P and Q CURVE

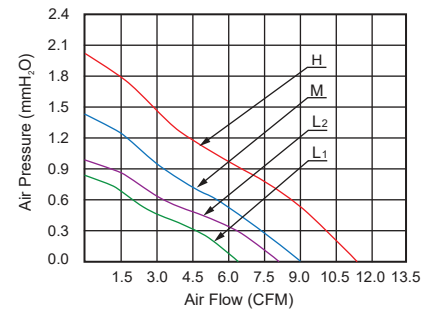

型号 Model	轴承类型 Bearing Type	风扇类型 Fan Type	电压 Rated Voltage	电流 Current	功率 Input Power	转速 Speed	风量 Air Flow	风压 Static Pressure	噪音 Noise Level
			VDC	Amp	Watt	RPM	CFM	MM-H ₂ O	dB-A
CC6008L05SH	Hydraulic	Frameless	5V	0.10	0.50	2000±10%	6.20	0.85	18.0
CC6008M05SH	Hydraulic	Frameless	5V	0.20	1.00	3000±10%	9.00	1.40	25.0
CC6008H05SH	Hydraulic	Frameless	5V	0.28	1.40	3500±10%	11.00	1.90	28.0
CC6008L12SH	Hydraulic	Frameless	12V	0.06	0.72	2500±10%	7.70	1.00	20.0
CC6008M12SH	Hydraulic	Frameless	12V	0.10	1.20	3000±10%	9.00	1.40	25.0
CC6008H12SH	Hydraulic	Frameless	12V	0.14	1.68	3500±10%	11.00	1.90	28.0
CC6008L24SH	Hydraulic	Frameless	24V	0.04	0.96	2500±10%	7.70	1.00	20.0
CC6008M24SH	Hydraulic	Frameless	24V	0.06	1.44	3000±10%	9.00	1.40	25.0
CC6008H24SH	Hydraulic	Frameless	24V	0.08	1.92	3500±10%	11.00	1.90	28.0

- * 以上为额定电压下的常规参数 (All readings are typical values at rated voltage)
- * 规格如有变动不另行通知 (Specifications are subjected to change without prior notice)

Frameless Fan $\Phi 55 \times 11 \text{mm}$

■ 尺寸图 (DIMENSION DRAWING)

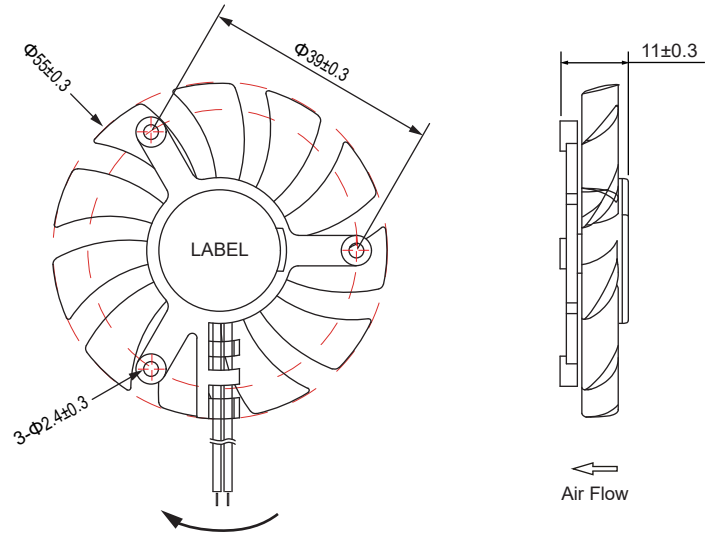

Unit:mm

■ 风压&风量曲线图 P and Q CURVE

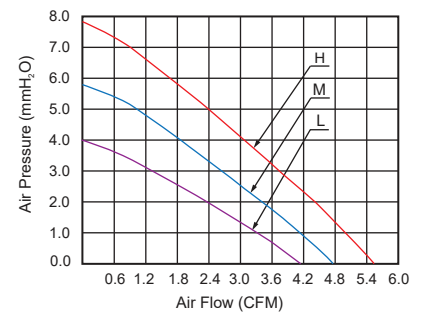

- * 轴承类型: 含油轴承, 双滚珠轴承 (Bearing type:Sleeve,2-Ball)
- * 材料(Material):
支架(Bracket):PBT 叶(Blade):PBT
- * 引线(Lead wire):
UL1061 AWG #26 or equivalent
红色线正级 Red Wire Positive (+)
黑色线负级 Black Wire Negative (-)
- * 可选择增加风扇功能(Functions are optional)
- * 重量(Weight):13.0g

型号 Model	轴承类型 Bearing Type	风扇类型 Fan Type	版本 Version	电压 Rated Voltage	电流 Current	转速 Speed	风量 Air Flow	风压 Static Pressure	噪音 Noise Level
				VDC	Amp	RPM	CFM	MM-H ₂ O	dBA
CC6010L05S	Sleeve	Frameless	-A	5V	0.13	3,000±10%	4.10	4.00	28.0
CC6010L05D	2-Ball								
CC6010M05S	Sleeve	Frameless	-A	5V	0.22	3,600±10%	4.70	5.70	32.0
CC6010M05D	2-Ball								
CC6010H05S	Sleeve	Frameless	-A	5V	0.50	4,200±10%	5.50	7.90	37.0
CC6010H05D	2-Ball								
CC6010L12S	Sleeve	Frameless	-A	12V	0.06	3,000±10%	4.10	4.00	28.0
CC6010L12D	2-Ball								
CC6010M12S	Sleeve	Frameless	-A	12V	0.11	3,600±10%	4.70	5.70	32.0
CC6010M12D	2-Ball								
CC6010H12S	Sleeve	Frameless	-A	12V	0.17	4,200±10%	5.50	7.90	37.0
CC6010H12D	2-Ball								

- * 以上为额定电压下的常规参数(All readings are typical values at rated voltage)
- * 规格如有变动不另行通知(Specifications are subjected to change without prior notice)

Frameless Fan $\Phi 55 \times 11.5 \text{mm}$

■ 尺寸图 (DIMENSION DRAWING)

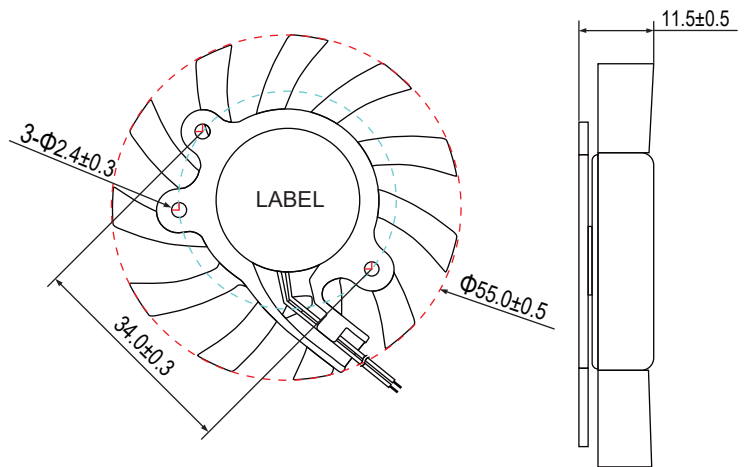

Unit:mm

- * 轴承类型: 含油轴承, 双滚珠轴承 (Bearing type:Sleeve,2-Ball)
- * 材料(Material):
框叶(Frame & Impeler):PBT
- * 引线(Lead wire):
UL2468 AWG #28 or equivalent
红色线正级 Red Wire Positive (+)
黑色线负级 Black Wire Negative (-)
- * 可选择增加风扇功能(Functions are optional)
- * 重量(Weight):13g

■ 风压&风量曲线图 P and Q CURVE

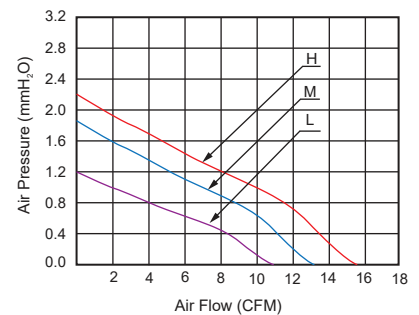

型号 Model	轴承类型 Bearing Type	风扇类型 Fan Type	版本 Version	电压 Rated Voltage	电流 Current	转速 Speed	风量 Air Flow	风压 Static Pressure	噪音 Noise Level
				VDC	Amp	RPM	CFM	MM-H ₂ O	dBA
CC6010L05S	Sleeve	Frameless	-B	5V	0.18	3,000±10%	11.00	1.20	22.0
CC6010L05D	2-Ball								
CC6010M05S	Sleeve	Frameless	-B	5V	0.23	3,500±10%	13.00	1.80	25.0
CC6010M05D	2-Ball								
CC6010H05S	Sleeve	Frameless	-B	5V	0.30	4,000±10%	15.50	2.20	28.0
CC6010H05D	2-Ball								
CC6010L12S	Sleeve	Frameless	-B	12V	0.08	3,000±10%	11.00	1.20	22.0
CC6010L12D	2-Ball								
CC6010M12S	Sleeve	Frameless	-B	12V	0.10	3,500±10%	13.00	1.80	25.0
CC6010M12D	2-Ball								
CC6010H12S	Sleeve	Frameless	-B	12V	0.13	4,000±10%	15.50	2.20	28.0
CC6010H12D	2-Ball								

- * 以上为额定电压下的常规参数(All readings are typical values at rated voltage)
- * 规格如有变动不另行通知(Specifications are subjected to change without prior notice)

Frameless Fan $\Phi 55 \times 11.5 \text{mm}$

■ 尺寸图 (DIMENSION DRAWING)

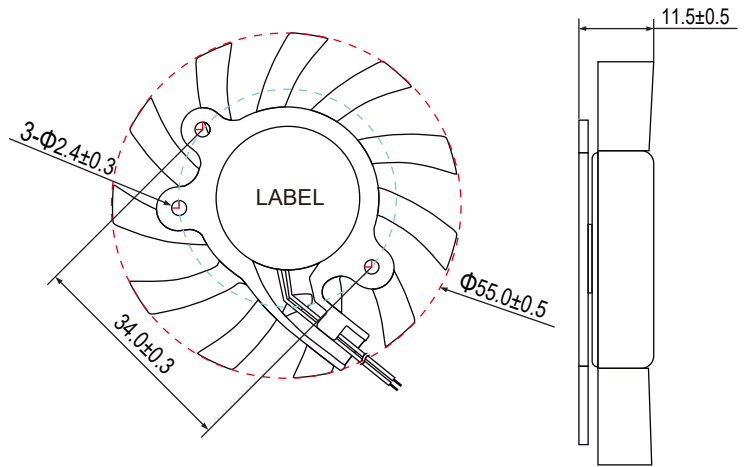

Unit:mm

- * 轴承类型: 含油轴承, 双滚珠轴承 (Bearing type:Sleeve,2-Ball)
- * 材料(Material):
框叶(Frame & Impeler):PBT
- * 引线(Lead wire):
UL2468 AWG #28 or equivalent
红色线正级 Red Wire Positive (+)
黑色线负级 Black Wire Negative (-)
- * 可选择增加风扇功能(Functions are optional)
- * 重量(Weight):13g

■ 风压&风量曲线图 P and Q CURVE

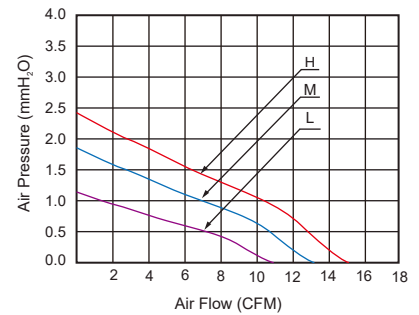

型号 Model	轴承类型 Bearing Type	风扇类型 Fan Type	版本 Version	电压 Rated Voltage	电流 Current	转速 Speed	风量 Air Flow	风压 Static Pressure	噪音 Noise Level
				VDC	Amp	RPM	CFM	MM-H ₂ O	dBA
CC6010L24S	Sleeve	Frameless	-B	24V	0.04	3,000±10%	11.00	1.20	22.0
CC6010L24D	2-Ball								
CC6010M24S	Sleeve	Frameless	-B	24V	0.05	3,500±10%	13.00	1.80	25.0
CC6010M24D	2-Ball								
CC6010H24S	Sleeve	Frameless	-B	24V	0.06	4,000±10%	15.50	2.20	28.0
CC6010H24D	2-Ball								

- * 以上为额定电压下的常规参数(All readings are typical values at rated voltage)
- * 规格如有变动不另行通知(Specifications are subjected to change without prior notice)

Frameless Fan $\Phi 65 \times 11 \text{mm}$

■ 尺寸图 (DIMENSION DRAWING)

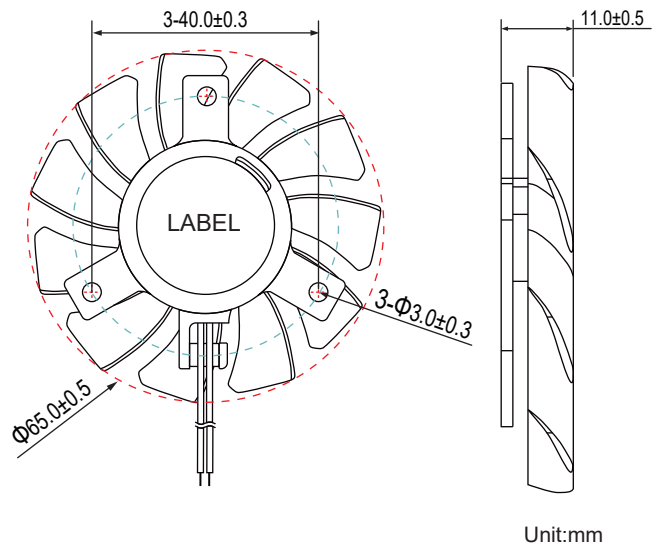

- * 轴承类型: 含油轴承, 双滚珠轴承 (Bearing type:Sleeve,2-Ball)
- * 材料(Material):
框叶(Frame & Impeller):PBT
- * 引线(Lead wire):
UL2468 AWG #28 or equivalent
红色线正级 Red Wire Positive (+)
黑色线负级 Black Wire Negative (-)
- * 可选择增加风扇功能(Functions are optional)
- * 重量(Weight):17g

■ 风压&风量曲线图 P and Q CURVE

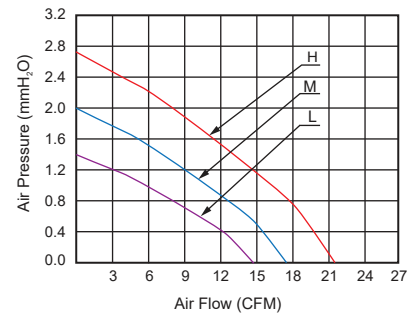

型号 Model	轴承类型 Bearing Type	风扇类型 Fan Type	电压 Rated Voltage	电流 Current	功率 Input Power	转速 Speed	风量 Air Flow	风压 Static Pressure	噪音 Noise Level
			VDC	Amp	Watt	RPM	CFM	MM-H ₂ O	dBA
CC7010L05S	Sleeve	Frameless	5V	0.18	0.90	2,500±10%	14.80	1.40	20.0
CC7010L05D	2-Ball								
CC7010M05S	Sleeve	Frameless	5V	0.25	1.25	3,000±10%	17.60	2.00	24.6
CC7010M05D	2-Ball								
CC7010H05S	Sleeve	Frameless	5V	0.32	1.60	3,500±10%	21.20	2.70	29.6
CC7010H05D	2-Ball								
CC7010L12S	Sleeve	Frameless	12V	0.07	0.84	2,500±10%	14.80	1.40	21.0
CC7010L12D	2-Ball								
CC7010M12S	Sleeve	Frameless	12V	0.10	1.20	3,000±10%	17.60	2.00	24.6
CC7010M12D	2-Ball								
CC7010H12S	Sleeve	Frameless	12V	0.14	1.68	3,500±10%	21.20	2.70	29.6
CC7010H12D	2-Ball								

- * 以上为额定电压下的常规参数(All readings are typical values at rated voltage)
- * 规格如有变动不另行通知(Specifications are subjected to change without prior notice)

Frameless Fan $\Phi 74 \times 11 \text{mm}$

■ 尺寸图 (DIMENSION DRAWING)

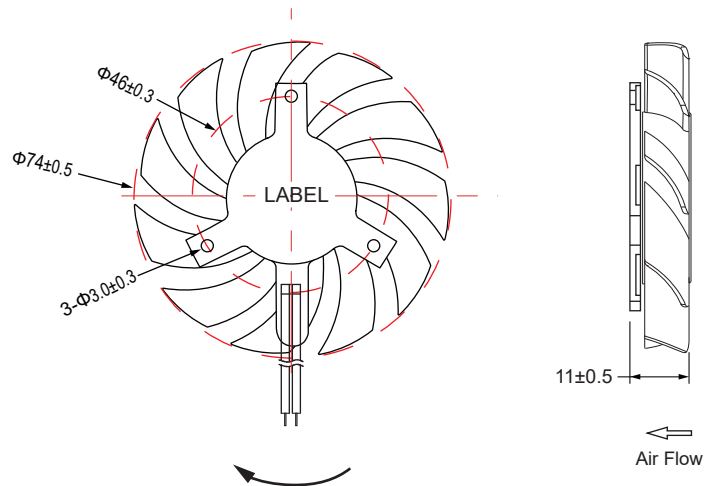

Unit:mm

■ 风压&风量曲线图 P and Q CURVE

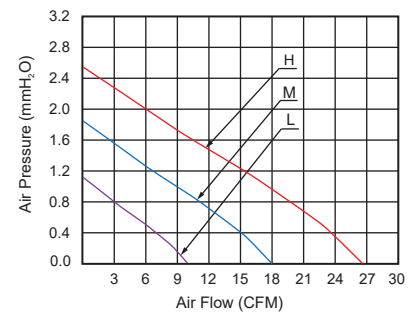

- * 轴承类型: 含油轴承, 双滚珠轴承 (Bearing type:Sleeve,2-Ball)
- * 材料(Material):
支架(Bracket):PBT 叶(Blade):PBT
- * 引线(Lead wire):
UL1061 AWG #26 or equivalent
红色线正级 Red Wire Positive (+)
黑色线负级 Black Wire Negative (-)
- * 可选择增加风扇功能(Functions are optional)
- * 重量(Weight):17.0g

型号 Model	轴承类型 Bearing Type	风扇类型 Fan Type	版本 Version	电压 Rated Voltage	电流 Current	转速 Speed	风量 Air Flow	风压 Static Pressure	噪音 Noise Level
				VDC	Amp	RPM	CFM	MM-H ₂ O	dBA
CC8010L12S	Sleeve	Frameless	-A	12V	0.07	2,500±10%	9.70	1.10	24.0
CC8010L12D	2-Ball								
CC8010M12S	Sleeve	Frameless	-A	12V	0.13	3,000±10%	18.0	1.80	28.0
CC8010M12D	2-Ball								
CC8010H12S	Sleeve	Frameless	-A	12V	0.30	3,500±10%	26.6	2.50	32.0
CC8010H12D	2-Ball								

- * 以上为额定电压下的常规参数(All readings are typical values at rated voltage)
- * 规格如有变动不另行通知(Specifications are subjected to change without prior notice)

Frameless Fan $\Phi 75 \times 17 \text{mm}$

■ 尺寸图 (DIMENSION DRAWING)

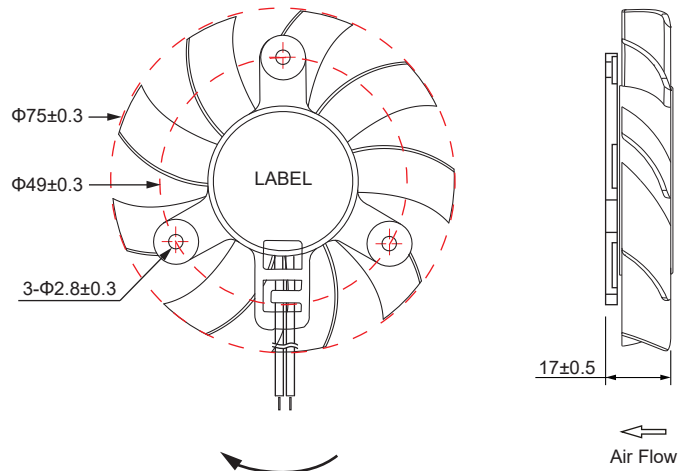

Unit:mm

■ 风压&风量曲线图 P and Q CURVE

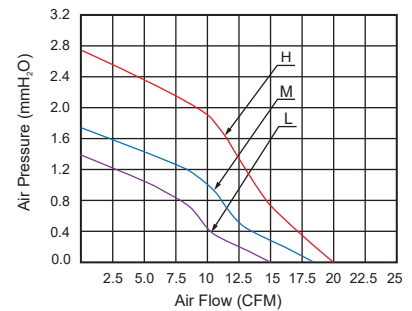

- * 轴承类型: 含油轴承, 双滚珠轴承 (Bearing type:Sleeve,2-Ball)
- * 材料(Material):
叶(Blade):PBT 支架(Bracket):PBT
- * 引线(Lead wire):
UL1061 AWG #26 or equivalent
红色线正级 Red Wire Positive (+)
黑色线负级 Black Wire Negative (-)
- * 可选择增加风扇功能(Functions are optional)
- * 重量(Weight):29.0g

型号 Model	轴承类型 Bearing Type	风扇类型 Fan Type	电压 Rated Voltage	电流 Current	功率 Input Power	转速 Speed	风量 Air Flow	风压 Static Pressure	噪音 Noise Level
			VDC	Amp	Watt	RPM	CFM	MM-H ₂ O	dBA
CC8015L05S	Sleeve	Frameless	5V	0.10	0.50	2,000±10%	15.0	1.40	25.0
CC8015L05D	2-Ball								
CC8015M05S	Sleeve	Frameless	5V	0.16	0.80	2,500±10%	18.2	1.80	29.0
CC8015M05D	2-Ball								
CC8015H05S	Sleeve	Frameless	5V	0.21	1.05	3,000±10%	20.0	2.60	35.0
CC8015H05D	2-Ball								
CC8015L12S	Sleeve	Frameless	12V	0.08	0.96	2,000±10%	15.0	1.40	25.0
CC8015L12D	2-Ball								
CC8015M12S	Sleeve	Frameless	12V	0.15	1.80	2,500±10%	18.2	1.80	29.0
CC8015M12D	2-Ball								
CC8015H12S	Sleeve	Frameless	12V	0.21	2.52	3,000±10%	20.0	2.60	35.0
CC8015H12D	2-Ball								

- * 以上为额定电压下的常规参数(All readings are typical values at rated voltage)
- * 规格如有变动不另行通知(Specifications are subjected to change without prior notice)

Frameless Fan $\Phi 74 \times 107 \times 23 \text{mm}$

■ 尺寸图 (DIMENSION DRAWING)

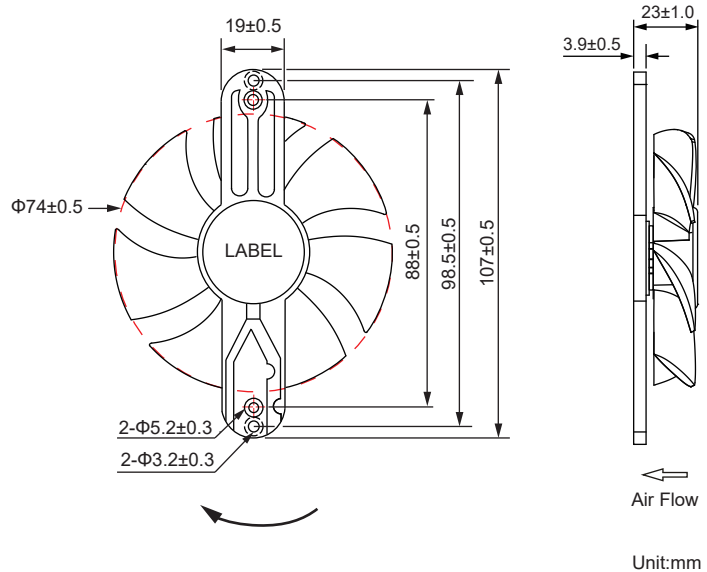
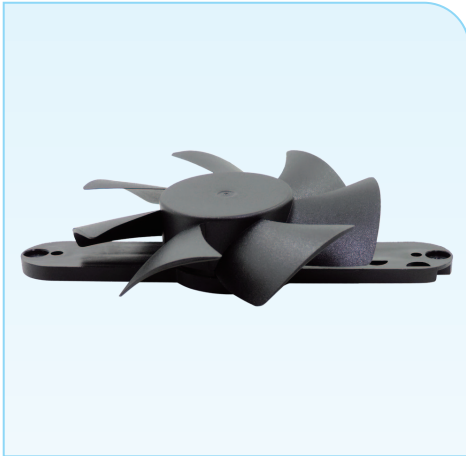

Unit:mm

- * 轴承类型: 含油轴承, 双滚珠轴承 (Bearing type:Sleeve,2-Ball)
- * 材料(Material):
支架(Bracket):PBT 叶(Blade):PBT
- * 引线(Lead wire):
UL1061 AWG #26 or equivalent
红色线正级 Red Wire Positive (+)
黑色线负级 Black Wire Negative (-)
- * 可选择增加风扇功能(Functions are optional)
- * 重量(Weight):35.0g

■ 风压&风量曲线图 P and Q CURVE

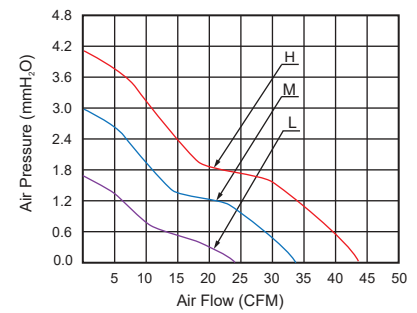

型号 Model	轴承类型 Bearing Type	风扇类型 Fan Type	电压 Rated Voltage	电流 Current	功率 Input Power	转速 Speed	风量 Air Flow	风压 Static Pressure	噪音 Noise Level
			VDC	Amp	Watt	RPM	CFM	MM-H ₂ O	dBA
CC8025L12S	Sleeve	Frameless	12V	0.08	0.96	2,000±10%	24.0	1.60	24.0
CC8025L12D	2-Ball								
CC8025M12S	Sleeve	Frameless	12V	0.15	1.80	2,500±10%	33.0	3.00	30.0
CC8025M12D	2-Ball								
CC8025H12S	Sleeve	Frameless	12V	0.19	2.28	3,000±10%	43.0	4.10	35.0
CC8025H12D	2-Ball								
CC8025L18S	Sleeve	Frameless	18V	0.06	1.08	2,000±10%	24.0	1.60	24.0
CC8025L18D	2-Ball								
CC8025M18S	Sleeve	Frameless	18V	0.08	1.44	2,500±10%	28.7	2.30	30.0
CC8025M18D	2-Ball								
CC8025H18S	Sleeve	Frameless	18V	0.10	1.80	3,000±10%	33.0	3.10	35.0
CC8025H18D	2-Ball								

- * 以上为额定电压下的常规参数(All readings are typical values at rated voltage)
- * 规格如有变动不另行通知(Specifications are subjected to change without prior notice)

Frameless Fan Φ83x120x23mm

■ 尺寸图 (DIMENSION DRAWING)

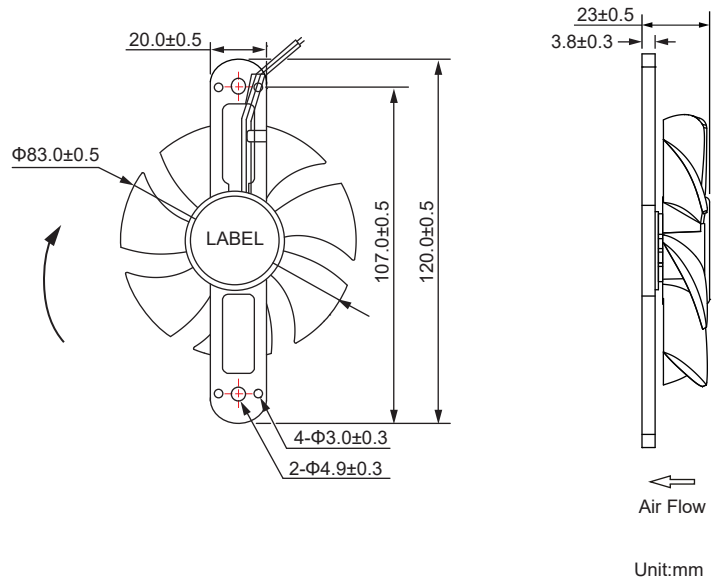

Unit:mm

■ 风压&风量曲线图 P and Q CURVE

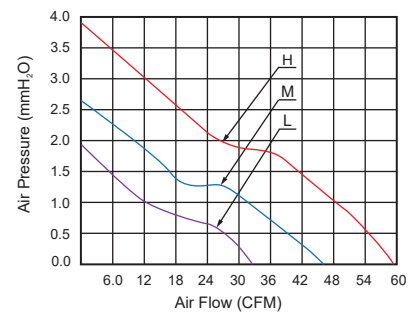

- * 轴承类型: 含油轴承, 双滚珠轴承 (Bearing type:Sleeve,2-Ball)
- * 材料(Material):
支架(Bracket):PBT 叶(Blade):PBT
- * 引线(Lead wire):
UL1061 AWG #26 or equivalent
红色线正级 Red Wire Positive (+)
黑色线负级 Black Wire Negative (-)
- * 可选择增加风扇功能(Functions are optional)
- * 重量(Weight):48.0g

型号 Model	轴承类型 Bearing Type	风扇类型 Fan Type	电压 Rated Voltage	电流 Current	功率 Input Power	转速 Speed	风量 Air Flow	风压 Static Pressure	噪音 Noise Level
			VDC	Amp	Watt	RPM	CFM	MM-H ₂ O	dBA
CC9225L12S	Sleeve	Frameless	12V	0.11	1.32	2,000±10%	32.6	1.90	27.0
CC9225L12D	2-Ball								
CC9225M12S	Sleeve	Frameless	12V	0.15	1.80	2,500±10%	45.8	2.60	32.0
CC9225M12D	2-Ball								
CC9225H12S	Sleeve	Frameless	12V	0.22	2.64	3,000±10%	59.3	3.90	37.0
CC9225H12D	2-Ball								
CC9225L18S	Sleeve	Frameless	18V	0.13	2.34	2,000±10%	32.6	1.90	27.0
CC9225L18D	2-Ball								
CC9225M18S	Sleeve	Frameless	18V	0.16	2.88	2,500±10%	45.8	2.60	32.0
CC9225M18D	2-Ball								
CC9225H18S	Sleeve	Frameless	18V	0.17	3.06	3,000±10%	59.3	3.90	37.0
CC9225H18D	2-Ball								

* 以上为额定电压下的常规参数(All readings are typical values at rated voltage)
* 规格如有变动不另行通知(Specifications are subjected to change without prior notice)

Frameless Fan $\Phi 102 \times 146 \times 23 \text{mm}$

■ 尺寸图 (DIMENSION DRAWING)

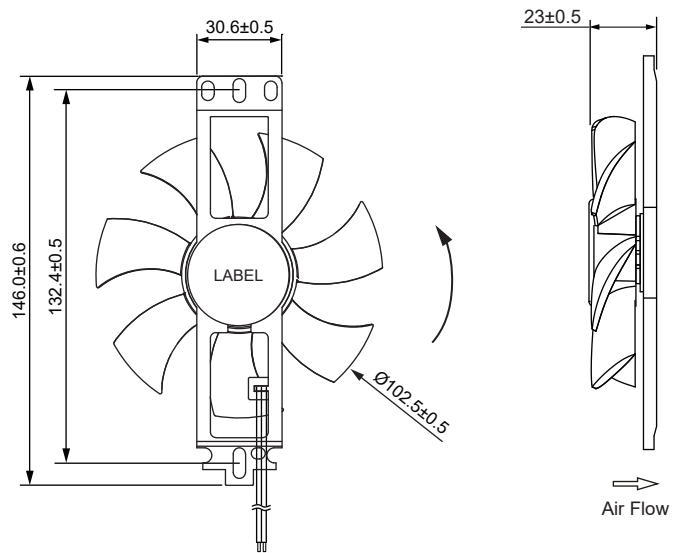
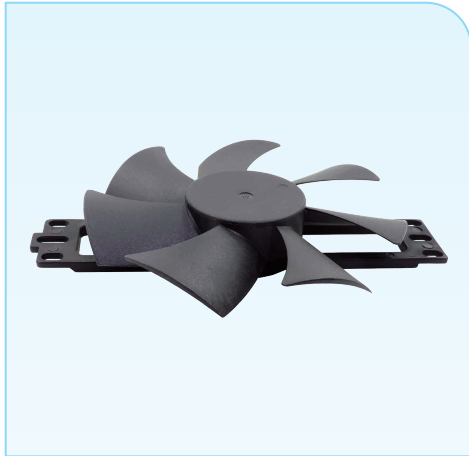

Unit:mm

■ 风压&风量曲线图 P and Q CURVE

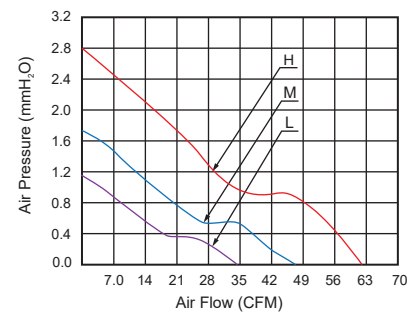

- * 轴承类型: 含油轴承, 双滚珠轴承 (Bearing type:Sleeve,2-Ball)
- * 材料(Material):
支架(Bracket):PBT 叶(Blade):PBT
- * 引线(Lead wire):
UL2468 AWG #26 or equivalent
红色线正级 Red Wire Positive (+)
黑色线负级 Black Wire Negative (-)
- * 可选择增加风扇功能(Functions are optional)
- * 重量(Weight):69.0g

型号 Model	轴承类型 Bearing Type	风扇类型 Fan Type	版本 Version	电压 Rated Voltage	电流 Current	转速 Speed	风量 Air Flow	风压 Static Pressure	噪音 Noise Level
				VDC	Amp	RPM	CFM	MM-H ₂ O	dBA
CC12025L12S	Sleeve	Frameless	-A	12V	0.11	1,400±10%	34.0	1.10	21.2
CC12025L12D	2-Ball								
CC12025M12S	Sleeve	Frameless	-A	12V	0.16	1,800±10%	46.0	1.70	28.0
CC12025M12D	2-Ball								
CC12025H12S	Sleeve	Frameless	-A	12V	0.25	2,200±10%	61.0	2.80	34.5
CC12025H12D	2-Ball								
CC12025L18S	Sleeve	Frameless	-A	18V	0.08	1,400±10%	34.0	1.10	21.0
CC12025L18D	2-Ball								
CC12025M18S	Sleeve	Frameless	-A	18V	0.12	1,800±10%	46.0	1.70	28.0
CC12025M18D	2-Ball								
CC12025H18S	Sleeve	Frameless	-A	18V	0.15	2,200±10%	61.0	2.80	34.5
CC12025H18D	2-Ball								

- * 以上为额定电压下的常规参数(All readings are typical values at rated voltage)
- * 规格如有变动不另行通知(Specifications are subjected to change without prior notice)

Frameless Fan Φ113x146x24mm

■ 尺寸图 (DIMENSION DRAWING)

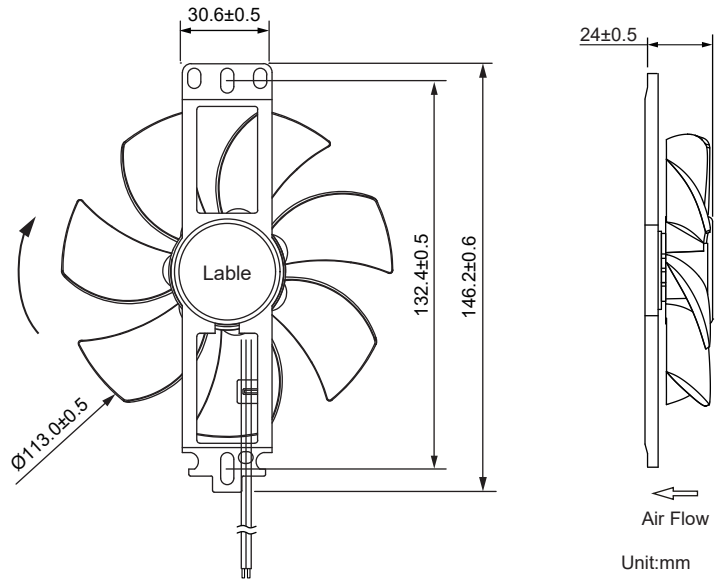
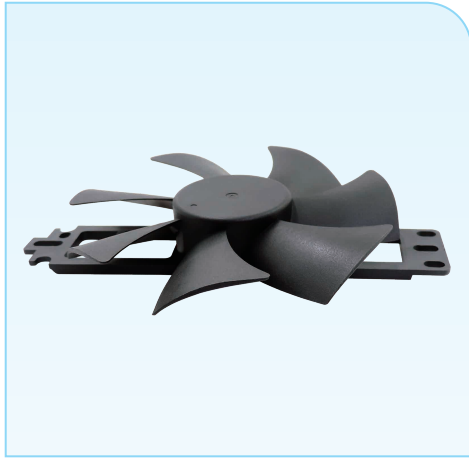

■ 风压&风量曲线图 P and Q CURVE

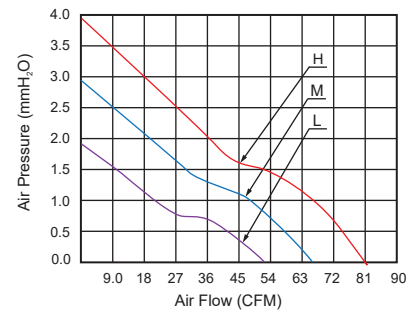

- * 轴承类型: 含油轴承, 双滚珠轴承 (Bearing type:Sleeve,2-Ball)
- * 材料(Material):
支架(Bracket):PBT 叶(Blade):PBT
- * 引线(Lead wire):
UL2468 AWG #26 or equivalent
红色线正级 Red Wire Positive (+)
黑色线负级 Black Wire Negative (-)
- * 可选择增加风扇功能(Functions are optional)
- * 重量(Weight):69.0g

型号 Model	轴承类型 Bearing Type	风扇类型 Fan Type	版本 Version	电压 Rated Voltage	电流 Current	转速 Speed	风量 Air Flow	风压 Static Pressure	噪音 Noise Level
				VDC	Amp	RPM	CFM	MM-H ₂ O	dBA
CC12025L12S	Sleeve	Frameless	-B	12V	0.11	1,400±10%	51.0	1.80	24.0
CC12025L12D	2-Ball								
CC12025M12S	Sleeve	Frameless	-B	12V	0.16	1,800±10%	66.0	2.90	31.0
CC12025M12D	2-Ball								
CC12025H12S	Sleeve	Frameless	-B	12V	0.25	2,200±10%	81.0	3.90	35.5
CC12025H12D	2-Ball								
CC12025L18S	Sleeve	Frameless	-B	18V	0.08	1,400±10%	51.0	1.80	24.0
CC12025L18D	2-Ball								
CC12025M18S	Sleeve	Frameless	-B	18V	0.13	1,800±10%	66.0	2.90	31.0
CC12025M18D	2-Ball								
CC12025H18S	Sleeve	Frameless	-B	18V	0.15	2,200±10%	81.0	3.90	35.5
CC12025H18D	2-Ball								

- * 以上为额定电压下的常规参数(All readings are typical values at rated voltage)
- * 规格如有变动不另行通知(Specifications are subjected to change without prior notice)

Frameless Blower Φ40x7mm

■ 尺寸图 (DIMENSION DRAWING)

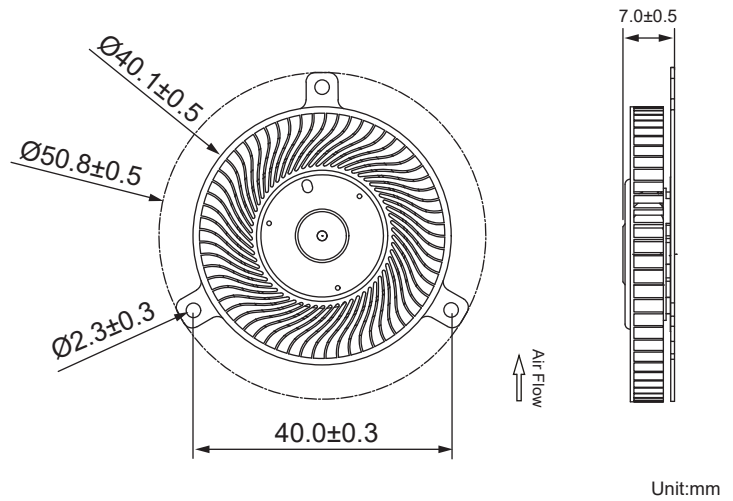

- * 轴承类型: 液压, 流体动压
(Bearing type:Hydraulic,FDB)
- * 材料(Material):
扇叶(Impeller):LCP
支架(Bracket):SGCC
- * 引线(Lead wire):
UL3302 AWG #30 or equivalent
红色线正级 Red Wire Positive (+)
黑色线负级 Black Wire Negative (-)
- * 可选择增加风扇功能(Functions are optional)
- * 重量(Weight):10g

■ 风压&风量曲线图 P and Q CURVE

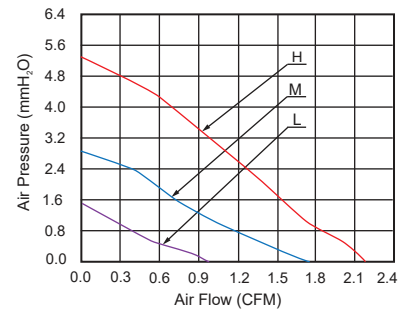

型号 Model	轴承类型 Bearing Type	版本 Version	电压 Rated Voltage	电流 Current	功率 Input Power	转速 Speed	风量 Air Flow	风压 Static Pressure	噪音 Noise Level
			VDC	Amp	Watt	RPM	CFM	MM-H ₂ O	dBA
BF4007L05SH	Hydraulic	-B	5V	0.10	0.50	3,200±10%	1.00	1.55	17.0
BF4007L05S3	FDB								
BF4007M05SH	Hydraulic	-B	5V	0.15	0.75	3,800±10%	1.70	2.80	18.0
BF4007M05S3	FDB								
BF4007H05SH	Hydraulic	-B	5V	0.25	1.25	4,400±10%	2.20	5.30	22.0
BF4007H05S3	FDB								
BF4007L12SH	Hydraulic	-B	12V	0.05	0.60	3,200±10%	1.00	1.55	17.0
BF4007L12S3	FDB								
BF4007M12SH	Hydraulic	-B	12V	0.10	1.20	3,800±10%	1.70	2.80	18.0
BF4007M12S3	FDB								
BF4007H12SH	Hydraulic	-B	12V	0.15	1.80	4,400±10%	2.20	5.30	22.0
BF4007H12S3	FDB								

- * 以上为额定电压下的常规参数(All readings are typical values at rated voltage)
- * 规格如有变动不另行通知(Specifications are subjected to change without prior notice)

Frameless Blower Φ36x10mm

■ 尺寸图 (DIMENSION DRAWING)

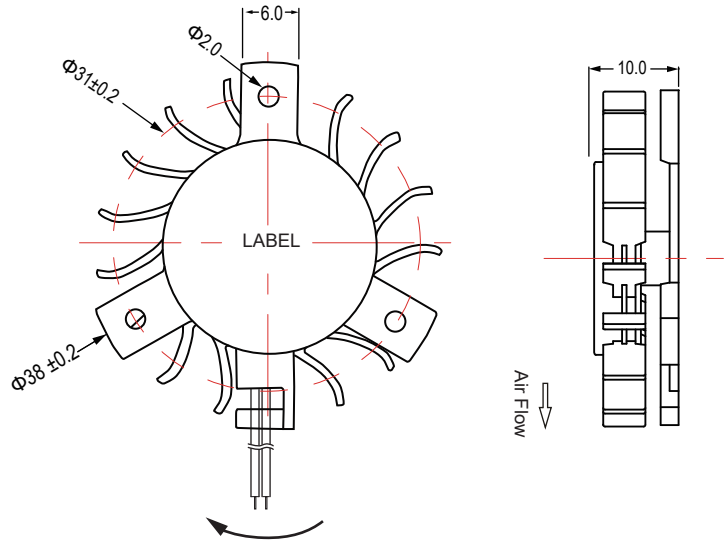

Unit:mm

- * 轴承类型: 含油轴承, 双滚珠轴承, 液压轴承
(Bearing type:Sleeve,2-Ball,Hydraulic)
- * 材料(Material):
支架(Bracket):PBT 叶(Impeller):PBT
- * 引线(Lead wire):
UL1061 AWG #26 or equivalent
红色线正级 Red Wire Positive (+)
黑色线负级 Black Wire Negative (-)
- * 可选择增加风扇功能(Functions are optional)
- * 重量(Weight):9.0g

型号 Model	轴承类型 Bearing Type	风扇类型 Fan Type	电压 Rated Voltage	电流 Current	功率 Input Power	转速 Speed	风量 Air Flow	风压 Static Pressure	噪音 Noise Level
			VDC	Amp	Watt	RPM	CFM	MM-H ₂ O	dBA
BF4010L05S	Sleeve	Frameless	5V	0.09	0.45	3,500±10%	---	---	20.0
BF4010L05D	2-Ball								
BF4010L05SH	Hydraulic								
BF4010M05S	Sleeve	Frameless	5V	0.16	0.80	4,000±10%	---	---	23.0
BF4010M05D	2-Ball								
BF4010M05SH	Hydraulic								
BF4010H05S	Sleeve	Frameless	5V	0.20	1.00	5,000±10%	---	---	26.0
BF4010H05D	2-Ball								
BF4010H05SH	Hydraulic								
BF4010L12S	Sleeve	Frameless	12V	0.10	1.20	3,500±10%	---	---	20.0
BF4010L12D	2-Ball								
BF4010L12SH	Hydraulic								
BF4010M12S	Sleeve	Frameless	12V	0.15	1.80	4,000±10%	---	---	23.0
BF4010M12D	2-Ball								
BF4010M12SH	Hydraulic								
BF4010H12S	Sleeve	Frameless	12V	0.17	2.04	5,000±10%	---	---	26.0
BF4010H12D	2-Ball								
BF4010H12SH	Hydraulic								

- * 以上为额定电压下的常规参数(All readings are typical values at rated voltage)
- * 规格如有变动不另行通知(Specifications are subjected to change without prior notice)

Frameless Blower Φ45x10mm

■ 尺寸图 (DIMENSION DRAWING)

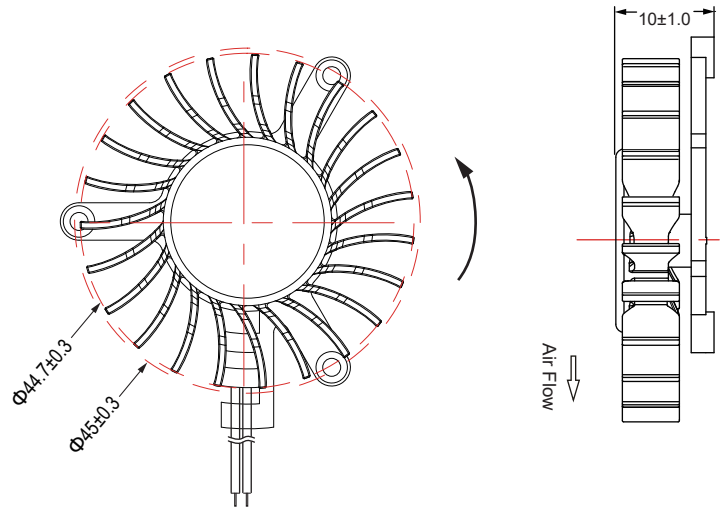

Unit:mm

- * 轴承类型: 含油轴承, 双滚珠轴承
(Bearing type:Sleeve,2-Ball)
- * 材料(Material):
支架(Bracket):PBT 叶(Impeller):PBT
- * 引线(Lead wire):
UL1061 AWG #26 or equivalent
红色线正级 Red Wire Positive (+)
黑色线负级 Black Wire Negative (-)
- * 可选择增加风扇功能(Functions are optional)
- * 重量(Weight):11.0g

型号 Model	轴承类型 Bearing Type	风扇类型 Fan Type	电压 Rated Voltage	电流 Current	功率 Input Power	转速 Speed	风量 Air Flow	风压 Static Pressure	噪音 Noise Level
			VDC	Amp	Watt	RPM	CFM	MM-H ₂ O	dBA
BF5010L05S	Sleeve	Frameless	5V	0.08	0.40	3,000±10%	---	---	21.6
BF5010L05D	2-Ball								
BF5010M05S	Sleeve	Frameless	5V	0.19	0.95	3,500±10%	---	---	26.3
BF5010M05D	2-Ball								
BF5010H05S	Sleeve	Frameless	5V	0.35	1.75	4,000±10%	---	---	30.2
BF5010H05D	2-Ball								
BF5010L12S	Sleeve	Frameless	12V	0.05	0.60	3,000±10%	---	---	21.6
BF5010L12D	2-Ball								
BF5010M12S	Sleeve	Frameless	12V	0.13	1.56	4,000±10%	---	---	30.2
BF5010M12D	2-Ball								
BF5010H12S	Sleeve	Frameless	12V	0.20	2.40	5,000±10%	---	---	32.6
BF5010H12D	2-Ball								

- * 以上为额定电压下的常规参数(All readings are typical values at rated voltage)
- * 规格如有变动不另行通知(Specifications are subjected to change without prior notice)

Frameless Blower Φ60.5x15mm

■ 尺寸图 (DIMENSION DRAWING)

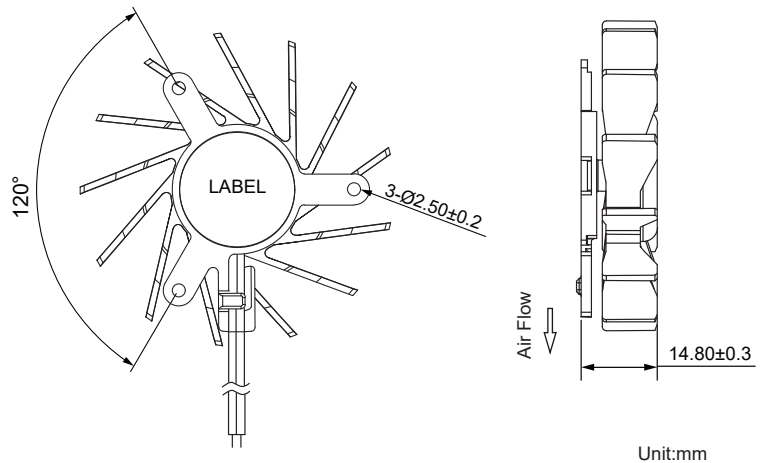

Unit:mm

- * 轴承类型: 液压轴承
(Bearing type:Hydraulic)
- * 材料(Material):
支架(Bracket):PBT 叶(Impeller):PBT
- * 引线(Lead wire):
UL1571AWG #28 or equivalent
红色线正级 Red Wire Positive (+)
黑色线负级 Black Wire Negative (-)
- * 可选择增加风扇功能(Functions are optional)
- * 重量(Weight):20.0g

型号 Model	轴承类型 Bearing Type	电压 Rated Voltage	电压范围 Operation Voltage	电流 Current	功率 Input Power	转速 Speed	风量 Air Flow	风压 Static Pressure	噪音 Noise Level
		VDC	VDC	Amp	Watt	RPM	CFM	MM-H ₂ O	dBA
BF8015L05SH	Hydraulic	5V	4.5~5.5	0.25	1.25	2,100±10%	---	---	18.0
BF8015M05SH	Hydraulic	5V	4.5~5.5	0.36	1.80	2,400±10%	---	---	20.0
BF8015H05SH	Hydraulic	5V	4.5~5.5	0.44	2.20	2,600±10%	---	---	23.0

- * 以上为额定电压下的常规参数(All readings are typical values at rated voltage)
- * 规格如有变动不另行通知(Specifications are subjected to change without prior notice)

Frameless Blower Φ64x15mm

■ 尺寸图 (DIMENSION DRAWING)

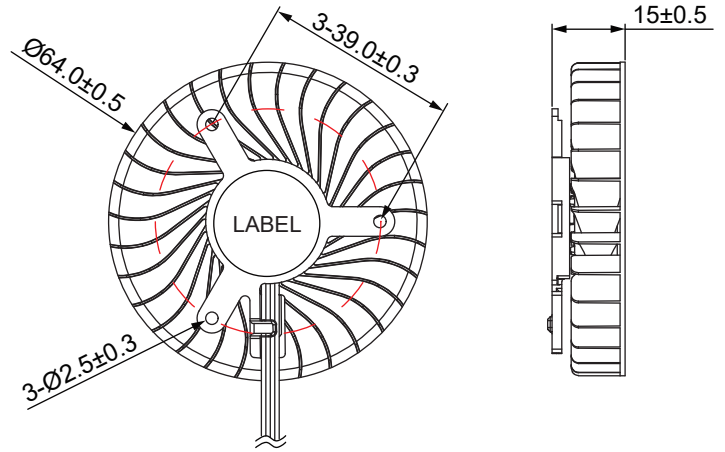

Unit:mm

- * 轴承类型: 液压轴承
(Bearing type:Hydraulic)
- * 材料(Material):
支架(Bracket):PBT 叶(Impeller):PBT
- * 引线(Lead wire):
UL1571AWG #28 or equivalent
红色线正级 Red Wire Positive (+)
黑色线负级 Black Wire Negative (-)
- * 可选择增加风扇功能(Functions are optional)
- * 重量(Weight):25.0g

型号 Model	轴承类型 Bearing Type	版本 Version	电压 Rated Voltage	电流 Current	功率 Input Power	转速 Speed	风量 Air Flow	风压 Static Pressure	噪音 Noise Level
			VDC	Amp	Watt	RPM	CFM	MM-H ₂ O	dBA
BF8015L05SH	Hydraulic	-B	5V	0.07	0.35	1,300±10%	---	---	16.0
BF8015M05SH	Hydraulic	-B	5V	0.16	0.80	1,700±10%	---	---	17.0
BF8015H05SH	Hydraulic	-B	5V	0.28	1.40	2,000±10%	---	---	18.0
BF8015L12SH	Hydraulic	-B	12V	0.05	0.60	1,300±10%	---	---	16.0
BF8015M12SH	Hydraulic	-B	12V	0.08	0.96	1,700±10%	---	---	17.0
BF8015H12SH	Hydraulic	-B	12V	0.14	1.68	2,000±10%	---	---	18.0

- * 以上为额定电压下的常规参数(All readings are typical values at rated voltage)
- * 规格如有变动不另行通知(Specifications are subjected to change without prior notice)

Frameless Blower Φ74x25mm

■ 尺寸图 (DIMENSION DRAWING)

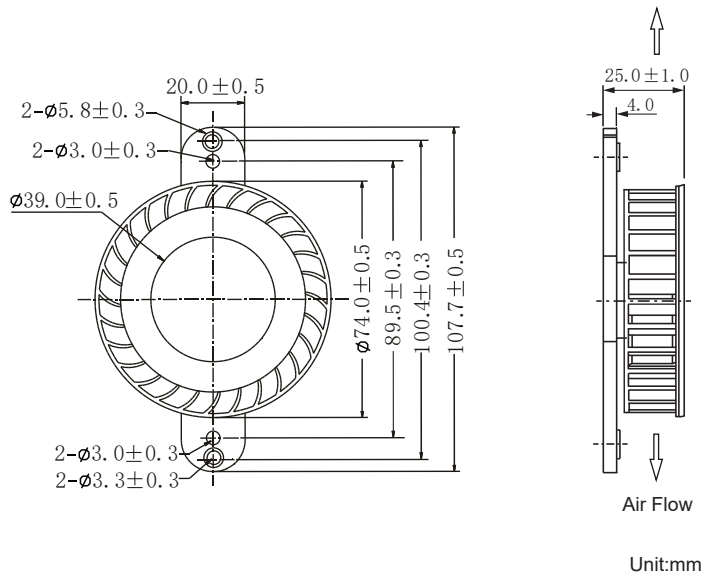

- * 轴承类型: 含油轴承, 双滚珠轴承 (Bearing type:Sleeve,2-Ball)
- * 材料(Material):
支架(Bracket):PBT 叶(Impeller):PBT
- * 引线(Lead wire):
UL2468 AWG #26 or equivalent
红色线正级 Red Wire Positive (+)
黑色线负级 Black Wire Negative (-)
- * 可选择增加风扇功能(Functions are optional)
- * 重量(Weight):50.0g

型号 Model	轴承类型 Bearing Type	风扇类型 Fan Type	电压 Rated Voltage	电流 Current	功率 Input Power	转速 Speed	风量 Air Flow	风压 Static Pressure	噪音 Noise Level
			VDC	Amp	Watt	RPM	CFM	MM-H ₂ O	dBA
BF7525L05S	Sleeve	Frameless	5V	0.30	1.50	2,500 \pm 10%	---	---	31.5
BF7525L05D	2-Ball								
BF7525M05S	Sleeve	Frameless	5V	0.43	2.15	3,000 \pm 10%	---	---	35.6
BF7525M05D	2-Ball								
BF7525H05S	Sleeve	Frameless	5V	0.72	3.60	3,500 \pm 10%	---	---	40.0
BF7525H05D	2-Ball								
BF7525L12S	Sleeve	Frameless	12V	0.12	1.44	2,500 \pm 10%	---	---	31.5
BF7525L12D	2-Ball								
BF7525M12S	Sleeve	Frameless	12V	0.23	2.76	3,000 \pm 10%	---	---	35.6
BF7525M12D	2-Ball								
BF7525H12S	Sleeve	Frameless	12V	0.32	3.84	3,500 \pm 10%	---	---	40.0
BF7525H12D	2-Ball								

- * 以上为额定电压下的常规参数(All readings are typical values at rated voltage)
- * 规格如有变动不另行通知(Specifications are subjected to change without prior notice)

Frameless Blower Φ100x25.5mm

■ 尺寸图 (DIMENSION DRAWING)

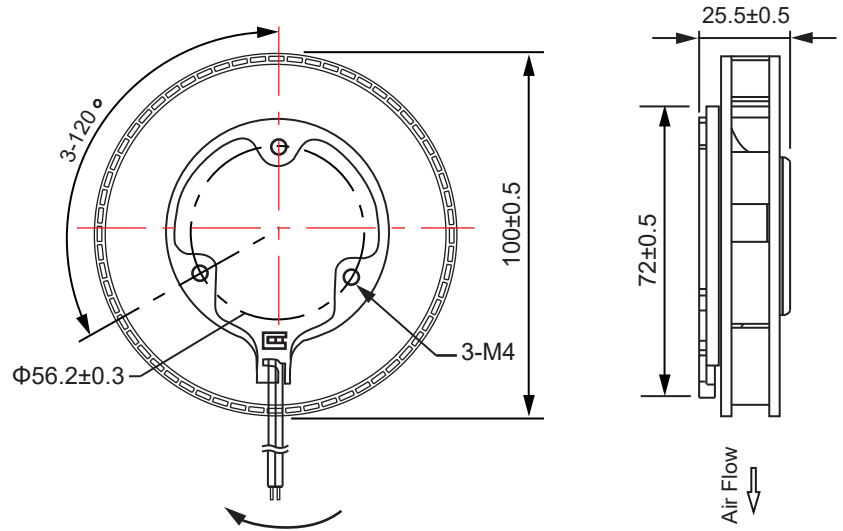

- * 轴承类型: 双滚珠轴承 (Bearing type: 2-Ball)
- * 材料(Material):
支架(Bracket): PPS 叶(Impeller): PBT
- * 引线(Lead wire):
UL2468 AWG #26 or equivalent
红色线正级 Red Wire Positive (+)
黑色线负级 Black Wire Negative (-)
- * 可选择增加风扇功能(Functions are optional)
- * 重量(Weight): 120g

■ 风压&风量曲线图 P and Q CURVE

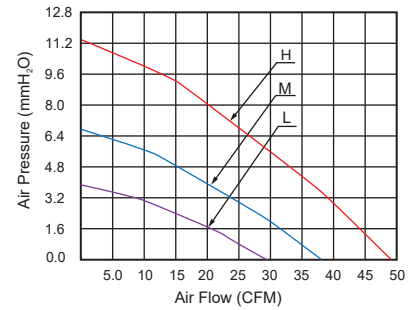

型号 Model	轴承类型 Bearing Type	风扇类型 Fan Type	电压 Rated Voltage	电流 Current	功率 Input Power	转速 Speed	风量 Air Flow	风压 Static Pressure	噪音 Noise Level
			VDC	Amp	Watt	RPM	CFM	MM-H ₂ O	dBA
BF10025L12D	2-Ball	Frameless	12	0.18	2.16	3,000±10%	28.2	3.80	41.0
BF10025M12D	2-Ball	Frameless	12	0.40	4.80	4,000±10%	37.5	6.70	49.5
BF10025H12D	2-Ball	Frameless	12	0.80	9.60	5,000±10%	49.0	11.3	56.8
BF10025L24D	2-Ball	Frameless	24	0.10	2.40	3,000±10%	28.2	3.80	41.0
BF10025M24D	2-Ball	Frameless	24	0.20	4.80	4,000±10%	37.5	6.70	49.5
BF10025H24D	2-Ball	Frameless	24	0.40	9.60	5,000±10%	49.0	11.3	56.8

- * 以上为额定电压下的常规参数(All readings are typical values at rated voltage)
- * 规格如有变动不另行通知(Specifications are subjected to change without prior notice)

Frameless Blower Φ107x26mm

■ 尺寸图 (DIMENSION DRAWING)

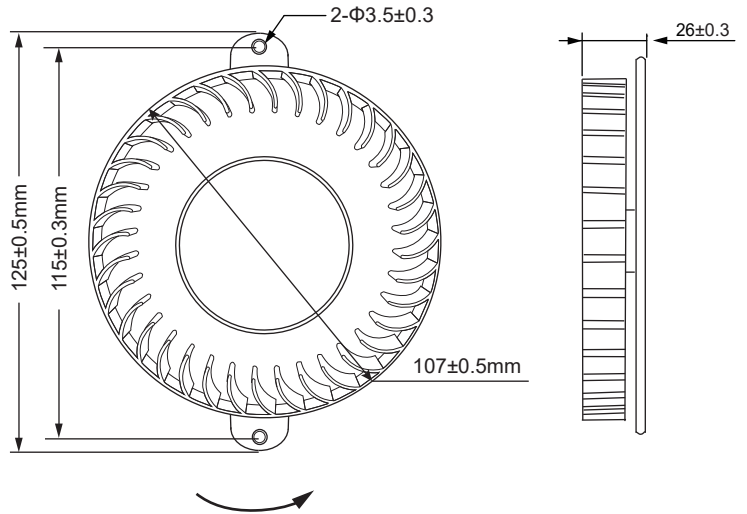

Unit:mm

■ 风压&风量曲线图 P and Q CURVE

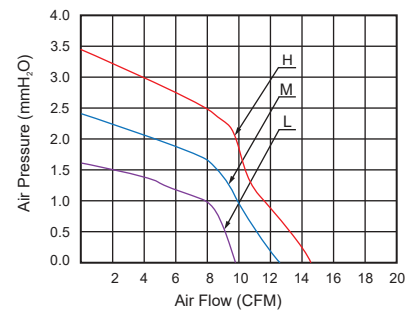

- * 轴承类型: 含油轴承 (Bearing type:Sleeve)
- * 材料(Material): 支架(Bracket):PP 叶(Impeller):PBT
- * 引线(Lead wire): UL2468 AWG #26 or equivalent
红色线正级 Red Wire Positive (+)
黑色线负级 Black Wire Negative (-)
- * 可选择增加风扇功能(Functions are optional)
- * 重量(Weight):114g

型号 Model	轴承类型 Bearing Type	风扇类型 Fan Type	电压 Rated Voltage	电流 Current	功率 Input Power	转速 Speed	风量 Air Flow	风压 Static Pressure	噪音 Noise Level
			VDC	Amp	Watt	RPM	CFM	MM-H ₂ O	dBA
BF11025L12S	Sleeve	Frameless	12	0.08	0.96	1,200±10%	9.80	1.60	33.5
BF11025M12S	Sleeve	Frameless	12	0.15	1.80	1,500±10%	12.3	2.30	38.1
BF11025H12S	Sleeve	Frameless	12	0.27	3.24	1,800±10%	14.4	3.40	43.0

- * 以上为额定电压下的常规参数(All readings are typical values at rated voltage)
- * 规格如有变动不另行通知(Specifications are subjected to change without prior notice)

Frameless Blower Φ120x26mm

■ 尺寸图 (DIMENSION DRAWING)

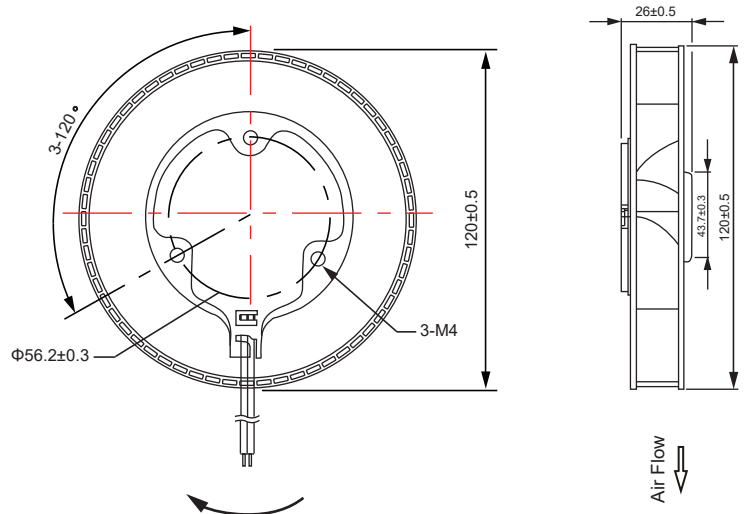

Unit:mm

■ 风压&风量曲线图 P and Q CURVE

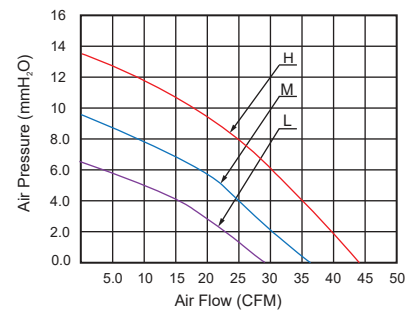

- * 轴承类型: 双滚珠轴承 (Bearing type:2-Ball)
- * 材料(Material):
支架(Bracket):PPS 叶(Impeller):PBT
- * 引线(Lead wire):
UL2468 AWG #26 or equivalent
红色线正级 Red Wire Positive (+)
黑色线负级 Black Wire Negative (-)
- * 可选择增加风扇功能(Functions are optional)
- * 重量(Weight):145g

型号 Model	轴承类型 Bearing Type	风扇类型 Fan Type	电压 Rated Voltage	电流 Current	功率 Input Power	转速 Speed	风量 Air Flow	风压 Static Pressure	噪音 Noise Level
			VDC	Amp	Watt	RPM	CFM	MM-H ₂ O	dBA
BF12025L12D	2-Ball	Frameless	12	0.20	2.40	2,000±10%	28.7	6.2	41.0
BF12025M12D	2-Ball	Frameless	12	0.40	4.80	2,500±10%	35.6	9.3	47.6
BF12025H12D	2-Ball	Frameless	12	0.60	7.20	3,000±10%	43.0	13.6	52.5
BF12025L24D	2-Ball	Frameless	24	0.11	2.64	2,000±10%	28.7	6.2	41.0
BF12025M24D	2-Ball	Frameless	24	0.22	5.28	2,500±10%	35.6	9.3	47.6
BF12025H24D	2-Ball	Frameless	24	0.40	9.60	3,000±10%	43.0	13.6	52.5

- * 以上为额定电压下的常规参数(All readings are typical values at rated voltage)
- * 规格如有变动不另行通知(Specifications are subjected to change without prior notice)